

ONE PIECE GAMING CHAIR



USER MANUAL

EN CONTENTS:

- 1 gaming chair
- 1 user manual

TECHNICAL SPECIFICATIONS:

- Chair dimensions: 52 x 50 x 123-132 cm
- 360° rotation
- Reclining backrest up to 150°
- Seat tilting up to 15°
- PVC leather
- Steel frame
- Metal base
- Foam padding
- 100mm class 4 gas lift
- 2D armrests
- 50mm casters

DE INHALT :

- 1 Gaming-Stuhl
- 1 Bedienungsanleitung

TECHNISCHE DATEN :

- Stuhlmaße: 52 x 50 x 123 - 132 cm
- 360°-Drehung
- Verstellbare Rückenlehne bis 150°
- Sitzkipfung bis 15°
- PVC-Leder
- Stahlrahmen
- Metallsockel
- Schaumstoffverkleidung
- 100 mm Gaslift der Klasse 4
- 2D-Armlehnen
- 50 mm-Rollen

FR CONTENU :

- 1 fauteuil gaming
- 1 mode d'emploi

CARACTÉRISTIQUES TECHNIQUES :

- Dimensions du fauteuil : 52 x 50 x 123-132 cm
- Rotation à 360°
- Dossier inclinable jusqu'à 150°
- Basculement de l'assise jusqu'à 15°
- Cuir synthétique
- Structure en acier
- Base métallique
- Rembourrage en mousse
- Colonne d'ascension par poussée de gaz 100 mm Catégorie 4
- Accoudoirs 2D
- Roulettes 50 mm

NL INHOUD:

- 1 gamingstoel
- 1 gebruikershandleiding

TECHNISCHE SPECIFICATIES:

- Afmetingen stoel: 52 x 50 x 123-132 cm
- Rotatie van 360°
- Rugleuning verstelbaar tot 150°
- Zit kantelbaar tot 15°
- PVC-leer
- Stalen frame
- Metalen basis
- Schuimvulling
- Gaslift klasse 4 van 100 mm
- 2D armleuningen
- 50 mm zwenkwielen

- EN Reclining backrest up to 150°
- FR Dossier inclinable jusqu'à 150°
- DE Verstellbare Rückenlehne bis 150°
- NL Rugleuning verstelbaar tot 150°



- EN Adjustable lumbar and neck pillows
- FR Supports lombaires et cou réglables
- DE Verstellbare Lenden- und Nackenkissen
- NL Verstelbare lende- en nekkussens

- EN Padded cushions
- FR Coussins rembourrés
- DE Gepolsterte Kissen
- NL Gewatteerde kussens













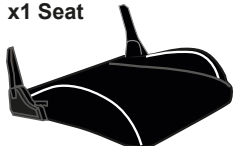

- EN 2D adjustable armrests
- FR Accoudoirs 2D réglables
- DE 2D verstellbare Armlehnen
- NL 2D armleuningen

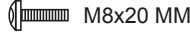
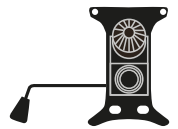
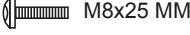
- EN 360° Rotation
- FR Rotation à 360°
- DE 360° Drehung
- NL Rotatie van 360°

PARTS LIST

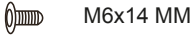
EN

ATTENTION: Before you begin the assembly make sure all parts are included and in good condition.

A x1 Back Rest 	F x1 Plastic covers (Set) 
B x1 Seat 	G x1 star base 
CR x1 Right arm 	H x5 caster 
CL x1 Left arm 	I x10 screws (Arms, mech.) M8x20 MM 
D x1 Mechanism 	J x4 screws (Back rest) M8x25 MM 
E x1 Hydraulic gas lift 	K x2 Cover 
P 	L x2 Screws (Back rest) M6x14 MM 
	M x14 
	N x14 
	O 
	Q 

ATTENTION:

- ⚠ Follow the instructions step by step.
- ⚠ To avoid misalignments, leave the screws loose and do not tighten them until all are in their respective places.
- ⚠ Do not overtighten or force the screws as they could break, strip, or damage the threads of the holes.
- ⚠ Using the wrong size of screws on a part could result in damage to the screw or the part.

1 FIRST REMOVE AND DISCARD THE PLASTIC CAP FROM THE TOP OF THE GAS CYLINDER (E).

insert the casters (H) into the base (G) using force. Finally, place the gas lift in the middle of the base and cover it with (F).

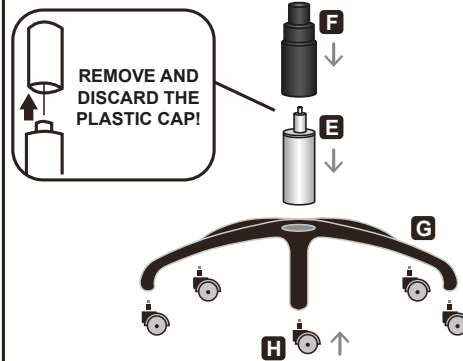

2 Place the seat (B) with its back towards you as shown. Using screws (I), and washers (M) and (N), assemble the mechanism (D) to the seat with its handle facing to your LEFT.

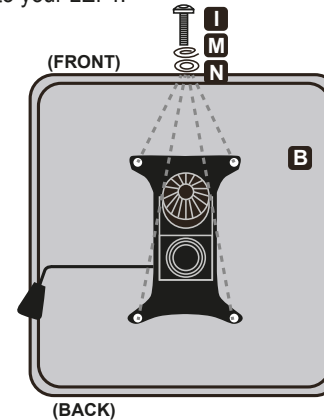

3 With the seat positioned as shown, assemble the RIGHT armrest (CR) on the LEFT and the LEFT armrest on the RIGHT using screws (I) and washers (M) and (N).

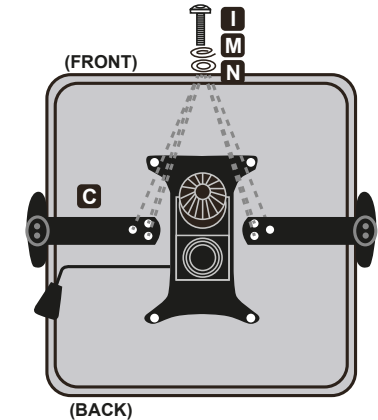

4 Using screws (J) and washers (M) and (N), assemble the backrest (A) to the metal brackets on the seat.



5 Attach the covers (K) to the metal brackets using screws (L). Then place the top of the chair over the base making sure the tip of the gas lift enters in the hole of the mechanism.

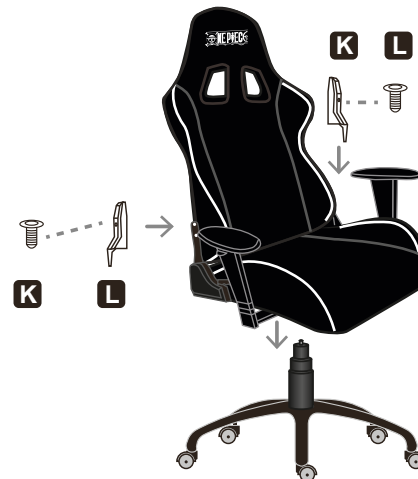















6 Strap the head pillow (P) at the top, and the lumbar pillow (Q) at the bottom of the backrest as shown. Adjust the pillows according to your needs.

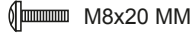
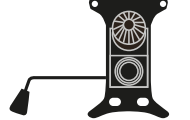
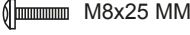

LISTE DES PIÈCES

FR

ATTENTION : Avant de commencer l'assemblage, assurez-vous que toutes les pièces sont incluses et en bon état.

A Dossier x1 	F Cache en plastique (ensemble) x1 
B Assise x1 	G Piétement en étoile x1 
CR Bras droit x1 	H Roulette x 5 
CL Bras gauche x1 	I Vis (Bras, méc.) x10 M8x20 MM 
D Mécanisme x1 	J Vis (Dossier) x4 M8x25 MM 
E Ascension par poussée de gaz x1 	K Cache x2 
P 	L Vis (Dossier) x2 M6x14 MM 
	M x14 
	N x14 
	O 
	Q 

ATTENTION :

- ⚠ Suivez les instructions, étape par étape.
- ⚠ Pour éviter les désalignements, laissez les vis desserrées et ne les serrez que lorsqu'elles sont toutes insérées à leur place respective.
- ⚠ Ne serrez pas trop et ne forcez pas sur les vis car elles pourraient casser, fendre ou endommager le filetage des trous.
- ⚠ Le fait d'utiliser des vis de mauvaise taille sur une pièce pourrait endommager la vis ou la pièce.

1 RETIREZ D'ABORD LE CACHE EN PLASTIQUE DU HAUT DE LA CARTOUCHE DE GAZ (E) ET JETEZ-LE.

Insérez ensuite en les poussant avec force les roulettes (H) dans la base (G). Enfin, placez le dispositif d'ascension par poussée de gaz au centre de la base et recouvrez-le avec (F).

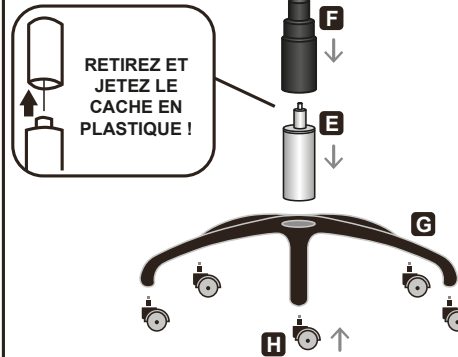

2 Placez l'assise (B) avec l'arrière orienté vers vous, tel qu'illustré. À l'aide des vis (I) et des rondelles (M) et (N), fixez le mécanisme (D) sur l'assise, avec la poignée tournée vers votre GAUCHE.

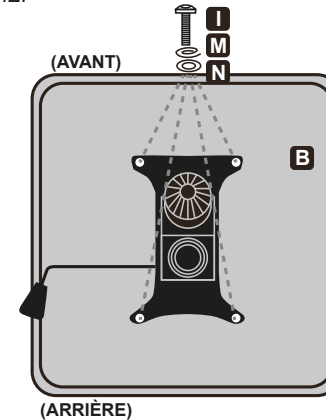

3 Une fois l'assise positionnée comme sur le schéma, montez l'accoudoir DROIT (CR) sur la GAUCHE et l'accoudoir GAUCHE sur la DROITE à l'aide des vis (I) et des rondelles (M) et (N).

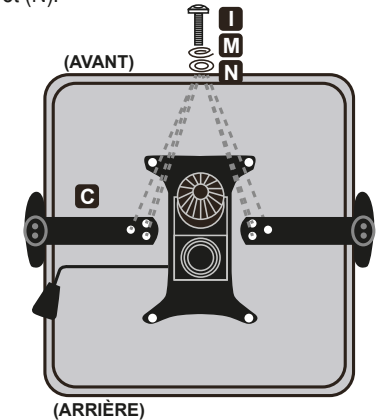

4 À l'aide des vis (J) et des rondelles (M) et (N), montez le dossier (A) sur les supports métalliques de l'assise.



5 Fixez les caches (K) aux supports métalliques à l'aide de vis (L). Ensuite, placez le dessus de la chaise sur la base en veillant à ce que l'extrémité du dispositif d'ascension par poussée de gaz entre dans le trou du mécanisme.

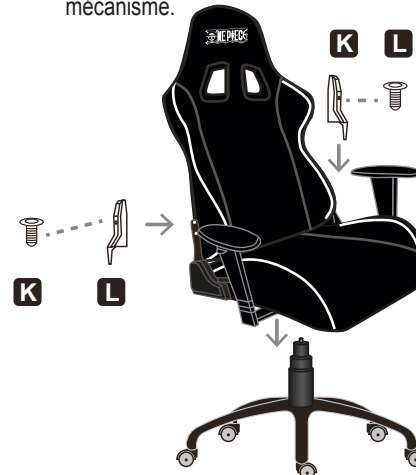













6 Attachez le support de tête (P) en haut et le support lombaire (Q) en bas du dossier, tel qu'illustré. Réglez les supports en fonction de vos besoins.

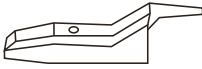
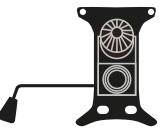

TEILELISTE

DE

ACHTUNG: Bevor Sie mit der Montage beginnen, vergewissern Sie sich, dass alle Teile enthalten und in gutem Zustand sind.

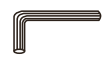
A x1 Rückenlehne	F x1 Kunststoffabdeckungen (Set)
	
B x1 Sitz	G x1 Sternsockel
	
CR x1 Rechter Arm	CL x1 Linker Arm
	
<small>Links/Rechts während man auf dem Stuhl sitzt.</small>	K x2 Abdeckung
D x1 Mechanismus	
	L x 2 Schrauben (Rückenlehne)
E x1 Hydraulischer Gaslift	
	M x14
P	
	N x14
Q	
	O
	

ACHTUNG:

- ⚠ Befolgen Sie die Anweisungen Schritt für Schritt.
- ⚠ Um Fehlausrichtungen zu verhindern, lassen Sie die Schrauben locker und ziehen Sie sie nicht fest, bis sich nicht alle an ihrem Platz befinden.
- ⚠ Ziehen Sie die Schrauben nicht zu fest an oder drücken Sie sie nicht, da sie die Gewinde der Bohrungen brechen, ausziehen oder beschädigen könnten.
- ⚠ Durch Verwendung einer falschen Schraubengröße kann es zu einer Beschädigung der Schraube oder des Teils kommen.

1 ENTFERNEN UND ENTSORGEN SIE ZUERST DIE KUNSTSTOFFKAPPE VON DER OBERSEITE DES GASZYLINDERS (E).

Drücken Sie dann die Rollen (H) in die Basis (G). Legen Sie schließlich den Gaslift in die Mitte der Basis und decken Sie ihn mit (F) ab.

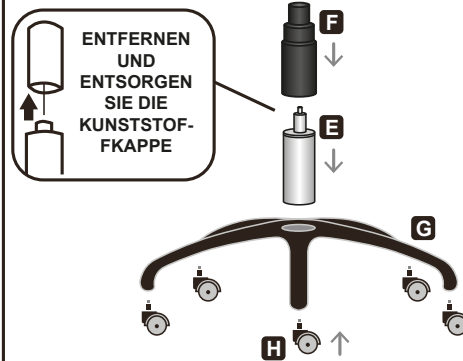

2 Legen Sie den Sitz (B) mit dem Rücken zu sich hin, wie dies gezeigt wird. Montieren Sie den Mechanismus (D) unter Einsatz der Schrauben (I) und Unterlegscheiben (M) und (N) mit dem Griff nach LINKS auf den Sitz.

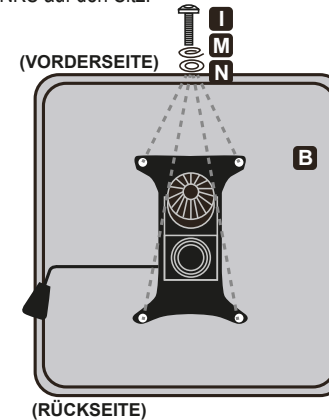

3 Montieren Sie die RECHTE Armlehne (CR) auf der LINKEN Seite und die LINKE Armlehne auf der RECHTEN Seite anhand der Schrauben (I) und Unterlegscheiben (M) und (N), der Sitz muss wie abgebildet positioniert sein.

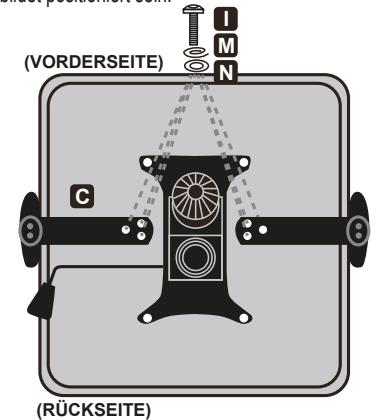

4 Montieren Sie die Rückenlehne (A) an den Metallhalterungen am Sitz unter Verwendung der Schrauben (J) und Unterlegscheiben (M) und (N).



5 Befestigen Sie die Abdeckungen (K) mit Schrauben (L) an den Metallhalterungen. Legen Sie dann die Oberseite des Stuhls über die Basis und vergewissern Sie sich, dass die Spitze des Gaslifts in die Bohrung des Mechanismus eintritt.

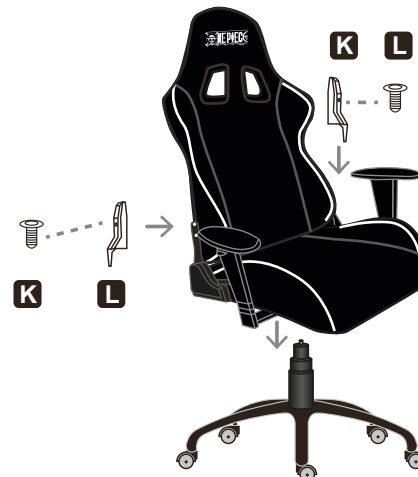















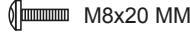

6 Schnallen Sie das Kopfkissen (P) oben und das Lendenkissen (Q) unten an der Rückenlehne an, wie dies gezeigt wird. Passen Sie die Kissen an Ihre Anforderungen an.

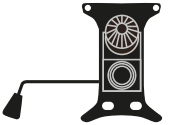
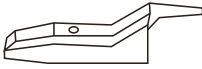

ONDERDELENLIJST

NL

LET OP: Zorg ervoor dat alle onderdelen zijn meegeleverd en in goede staat verkeren voordat u begint met de montage.

A x1 rugleuning	F x1 plastic afdekkingen (set)
	
B x1 zitting	G x1 sterrenbasis
	
CR x1 rechterarm	H x5 zwenkwiel
	
CL x1 linkerarm	I x10 schroeven (armen, mech.)
	 M8x20 MM
Links/rechts zoals u zit op de stoel.	J x4 schroeven (rugleuning)
D x1 mechanisme	 M8x25 MM
	K x2 afdekking
E x1 hydraulische gaslift	
	L x2 schroeven (Rugleuning)
P	 M6x14 MM
	M x14
Q	
	N x14
	
	O
	

LET OP:

- ⚠ Volg de instructies nauwgezet, stap voor stap.
- ⚠ Om verkeerde uitlijning te voorkomen, laat u de schroeven los en draait u ze niet vast totdat ze zich allemaal op hun respectievelijke plaatsen bevinden.
- ⚠ Draai de schroeven niet te strak aan of forceer ze niet: hierdoor kunnen ze de schroefdraden van de gaten breken, strippen of beschadigen.
- ⚠ Het gebruik van de verkeerde maat schroeven op een onderdeel kan leiden tot schade aan de schroef of het onderdeel.

1 VERWIJDER EERST DE PLASTIC DOP VAN DE BOVENKANT VAN DE GASCILINDER (E) EN GOOI DEZE WEG.

Steek vervolgens de zwenkwieken (H) met kracht in de basis (G). Plaats ten slotte de gaslift in het midden van de basis en bedek deze met (F).

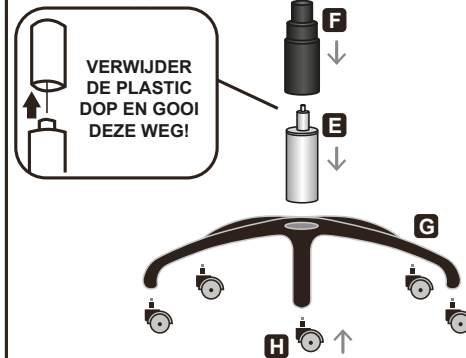

2 Plaats de stoel (B) met de rug naar u toe zoals afgebeeld. Monteer het mechanisme (D) met de schroeven (I) en sluitringen (M) en (N) op de zitting met de handgreep naar LINKS gericht.

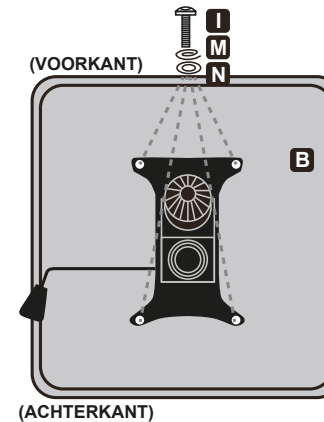

3 Met de stoel zoals afgebeeld monteert u de RECHTERarmsteun (CR) aan de LINKERKANT en de LINKERarmsteun aan de RECHTERKANT met behulp van de schroeven (I) en sluitringen (M) en (N).

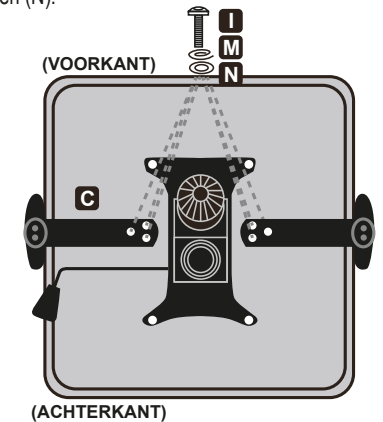

4 Monteer de rugleuning (A) en sluitringen (M) en (N) met behulp van schroeven (J) op de metalen beugels op de zitting.



5 Bevestig de afdekkingen (K) aan de metalen beugels met behulp van schroeven (L). Plaats vervolgens de bovenkant van de stoel over de basis en zorg ervoor dat de punt van de gaslift in het gat van het mechanisme komt.

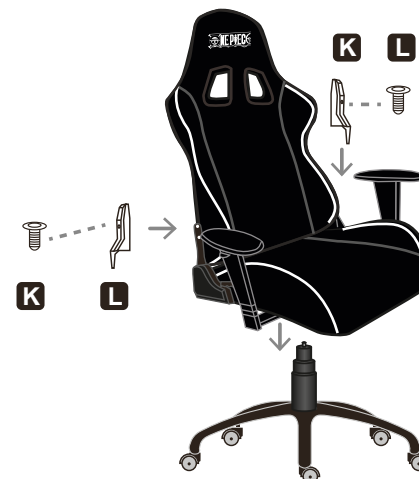

6 Maak het hoofdkussen (P) vast aan de bovenkant en het lendekussen (Q) aan de onderkant van de rugleuning zoals afgebeeld. Pas de kussens aan uw behoeften aan.



©Eiichiro Oda/Shueisha, Toei Animation

KONIX

www.konix-interactive.com

Konix. Innelec Multimedia - Konix, 45 rue Delizy, 93692 Pantin Cedex, FRANCE. The Konix brand is a trademark of Innelec Multimedia S.A. All other trademarks are the property of their respective owners. Photos and illustrations are not binding. All rights reserved. Made in PRC.

Konix. Innelec Multimedia - Konix, 45 rue Delizy, 93692 Pantin Cedex, FRANCE. La marque Konix est une marque déposée par Innelec Multimedia S.A. Toutes les autres marques commerciales appartiennent à leurs propriétaires respectifs. Les photos et les schémas sont non contractuels. Tous droits réservés. Fabriqué en RPC.

