

**MEDION®**

**Instruction Manual**

**43.9 cm / 17.3" Notebook**

---

# Table of Content

<b>1.</b>	<b>Information about these Operating Instructions .....</b>	<b>5</b>
1.1.	Explanation of Symbols .....	5
1.2.	Proper Use.....	7
<b>2.</b>	<b>EU Declaration of Conformity.....</b>	<b>7</b>
2.1.	Information on WLAN.....	8
<b>3.</b>	<b>Information on Trademarks .....</b>	<b>9</b>
<b>4.</b>	<b>Safety Instructions .....</b>	<b>9</b>
4.1.	Dangers for children and people with reduced ability to operate electronics.....	9
4.2.	Operational Safety .....	10
4.3.	Never carry out repairs yourself.....	12
4.4.	Setup Location .....	12
4.5.	Environmental Requirements.....	13
4.6.	Power Supply .....	14
4.7.	Notes on the Battery .....	15
4.8.	Cabling.....	16
4.9.	Information about the Touchpad.....	17
4.10.	Protecting the Display .....	17
4.11.	Data backup .....	18
4.12.	Ergonomics.....	18
<b>5.</b>	<b>Included with your Notebook.....</b>	<b>20</b>
<b>6.</b>	<b>Unpacking .....</b>	<b>20</b>
<b>7.</b>	<b>Views and description of the controls.....</b>	<b>21</b>
7.1.	Open Notebook .....	21
7.2.	Rear Side - Version 1 .....	22
7.3.	Rear Side - Version 2 .....	23
7.4.	Left Side - Version 1 .....	23
7.5.	Left Side - Version 2 .....	24
7.6.	Right Side - Version 1 .....	24
7.7.	Right Side - Version 2 .....	25
7.8.	Bottom View .....	25
	<b>Operating and Status LEDs.....</b>	<b>26</b>
<b>8.</b>	<b>Power Supply .....</b>	<b>26</b>
8.1.	On/Off Switch .....	26
<b>9.</b>	<b>Preparation for Starting-Up.....</b>	<b>27</b>
9.1.	Starting the Notebook .....	28
<b>10.</b>	<b>AC Power .....</b>	<b>28</b>
<b>11.</b>	<b>Battery Mode .....</b>	<b>29</b>
11.1.	General Handling of Rechargeable Batteries.....	29

---

<b>12.</b>	<b>Power Management (Power Options)</b> .....	<b>31</b>
12.1.	Energy Saving Tips .....	31
<b>13.</b>	<b>Display</b> .....	<b>32</b>
13.1.	Opening and Closing the Display .....	32
13.2.	Connecting an External Monitor .....	32
13.3.	Data Input .....	32
13.4.	Keyboard .....	32
13.5.	Touchpad .....	33
<b>14.</b>	<b>Sound System</b> .....	<b>34</b>
14.1.	External Audio Connections .....	34
<b>15.</b>	<b>Network Operation</b> .....	<b>34</b>
15.1.	Network Connection .....	34
15.2.	Wi-Fi (Wireless Network) .....	34
15.3.	Bluetooth® .....	36
15.4.	Airplane Mode .....	36
<b>16.</b>	<b>USB Port</b> .....	<b>36</b>
<b>17.</b>	<b>Securing Your Notebook</b> .....	<b>37</b>
17.1.	Password Setting (Power-on) .....	37
17.2.	Kensington Security Lock .....	37
17.3.	Fingerprint Sensor (optional) .....	37
<b>18.</b>	<b>Resetting the notebook to its Factory Settings</b> .....	<b>38</b>
18.1.	System recovery with PowerRecover (optional) .....	39
18.2.	System Restore with Windows Recovery Options .....	40
<b>19.</b>	<b>UEFI Configuration</b> .....	<b>41</b>
19.1.	Executing the UEFI Configuration .....	41
<b>20.</b>	<b>FAQs – Frequently Asked Questions</b> .....	<b>41</b>
<b>21.</b>	<b>Customer Service</b> .....	<b>43</b>
21.1.	What To Do in Case of Hardware Problems .....	43
21.2.	Find the Cause .....	43
21.3.	Do You Need More Help? .....	44
21.4.	Driver Support .....	44
21.5.	Transport .....	44
21.6.	Cleaning and Maintenance .....	45
21.7.	Storage when not in use .....	46
<b>22.</b>	<b>Upgrading/Modifying and Repair</b> .....	<b>46</b>
22.1.	Notes for Service Technicians .....	47
<b>23.</b>	<b>Disposal</b> .....	<b>47</b>
<b>24.</b>	<b>Information on Display Errors</b> .....	<b>48</b>
24.1.	European EN ISO 9241-307 Class II Standard .....	48

---

---

<b>25.</b>	<b>Battery Information.....</b>	<b>49</b>
<b>26.</b>	<b>Service information .....</b>	<b>50</b>
<b>27.</b>	<b>Legal Notice.....</b>	<b>51</b>
<b>28.</b>	<b>Privacy statement .....</b>	<b>51</b>
<b>29.</b>	<b>Index .....</b>	<b>52</b>

---

# 1. Information about these Operating Instructions



Thank you for choosing our product. We hope you enjoy using it. Read the safety instructions and all other instructions carefully before using the device for the first time. Note the warnings on the device and in the operating instructions.

Always keep the operating instructions close to hand. If you sell the device or give it away, please ensure that you also pass on these operating instructions. They are an essential component of the product.

## 1.1. Explanation of Symbols

If a block of text is marked with one of the warning symbols listed below, the hazard described in that text must be avoided to prevent the potential consequences described there from occurring.



### **DANGER!**

Warning of immediate risk of fatal injury!



### **WARNING!**

Warning: danger of electric shock!



### **WARNING!**

Warning: possible mortal danger and/or serious irreversible injuries!



### **WARNING!**

Warning: danger due to excessive volume!



### **CAUTION!**

Warning: possible light or moderate injuries!



### **NOTICE!**

Please follow the guidelines to avoid property damage.



Additional information on using the device.



Please follow the guidelines in the operating instructions.

- Bullet point/information on operating steps and results
- ▶ Tasks to be performed



Declaration of conformity (see section 'Declaration of conformity'): Products that feature this symbol meet the requirements of the EC directives.



Due to the 5 GHz frequency range of the used wireless LAN solution, use in EU countries is only permitted inside buildings.



### Indoor use

Devices with this symbol are only suitable for use indoors.

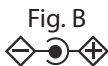

### Polarity symbols

On devices with barrel connectors, these symbols indicate the polarity of the plug. There are two variants for the polarity: either the inner contact is positive and the outer contact is negative (Fig. A) or the inner contact is negative and the outer contact is positive (Fig. B).



This symbol means that the packaging and/or device contains lithium batteries or rechargeable batteries.

---

## 1.2. Proper Use

This device is designed for the use, management and editing of electronic documents and multimedia content, as well as for digital communication. The device is intended for private use only and not for industrial/commercial use.

Please note that we shall not be liable in cases of improper use:

- Do not modify the device without our consent and use only spare parts and accessories which we have supplied or approved.
- Follow all instructions in this manual, especially the safety information. Any other use is deemed improper and can cause personal injury or damage to the product.
- Do not use the device in extreme environmental conditions.

## 2. EU Declaration of Conformity

MEDION AG hereby declares that this product conforms with the essential requirements and the remaining relevant regulations:

- RE Directive 2014/53/EU
- Ecodesign Directive 2009/125/EC (and Ecodesign Regulation 2019/1782)
- RoHS Directive 2011/65/EU

Full declarations of conformity are available at [www.medion.com/conformity](http://www.medion.com/conformity).



Use is only permitted inside buildings in all EU countries due to the 5 GHz frequency band of the inbuilt Wireless LAN solution.



AT	BE	BG	CZ	DK
EE	FR	DE	IS	IE
IT	EL	ES	CY	LV
LI	LT	LU	HU	MT
NL	NO	PL	PT	RO
SI	SK	TR	FI	SE
CH	UK(NI)	HR		

AT = Austria, BE = Belgium, BG = Bulgaria, CZ = Czech Republic, DK = Denmark, EE = Estonia, FR = France, DE = Germany, IS = Iceland, IE = Ireland, IT = Italy, EL = Greece, ES = Spain, CY = Cyprus, LV = Latvia, LI = Liechtenstein, LT = Lithuania, LU = Luxembourg, HU = Hungary, MT = Malta, NL = Netherlands, NO = Norway, PL = Poland, PT = Portugal, RO = Romania, SI = Slovenia, SK = Slovakia, TR = Turkey, FI = Finland, SE = Sweden, CH = Switzerland, UK(NI) = Northern Ireland, HR = Croatia

## 2.1. Information on WLAN

Frequency range: 2.4 GHz/5 GHz  
Wi-Fi standard: 802.11 a/b/g/n/ac  
Encryption: WEP/WPA/WPA2

Frequency range/MHz	Channel	Max. transmission power/ dBm
WLAN 2,4 Ghz 2400 - 2483,5	1 - 13	< 20
WLAN 5 Ghz 5150 - 5250	36 - 48	< 23
WLAN 5 Ghz 5250 - 5350	52 - 64	< 23
WLAN 5 Ghz 5470 - 5725	100 - 140	< 30
WLAN 5 Ghz 5735 - 5835	149 - 165	-- (if available < 14)



---

### 3. Information on Trademarks

Windows® is a registered trademark of Microsoft®. Intel®, the Intel® logo, Intel AMD, the AMD arrow logo, Ryzen, Radeon, Vega and combinations thereof are trademarks of Advanced Micro Devices, Inc. in the USA and/or in other countries.

The HDMI logo and High-Definition Multimedia Interface are registered trademarks of HDMI Licensing LLC.

The Bluetooth® word mark and logos are registered trademarks of Bluetooth SIG, Inc. and are used by MEDION under licence.

The USB™ word mark and logos are registered trademarks of USB Implementers Forum, Inc. and are used by MEDION under licence.

Other trademarks and brand names are the property of the respective owner.

### 4. Safety Instructions

#### 4.1. Dangers for children and people with reduced ability to operate electronics

This device may be used by children over the age of 8 and by persons with limited physical, sensory or mental abilities or by those without experience and knowledge, if they are supervised or have been instructed in the safe use of the device and understand the ensuing dangers.

- Children should be supervised to ensure that they do not play with the device.
- Cleaning and user maintenance must not be carried out by children unless they are supervised.
- Keep the device and accessories out of reach of children.



#### **DANGER!**

#### **Risk of suffocation!**

Packaging material is not a toy!

Packaging film can be swallowed or used improperly. Therefore, there is a risk of suffocation!

- ▶ Keep packaging material such as plastic film or plastic bags away from children.



## **WARNING!**

### **Impairment to hearing!**

Listening through earphones or headphones at excessive volume levels, as well as changes to the basic settings of the equaliser, drivers, software or operating system generates excessive acoustic pressure and can lead to damage or loss of hearing.

- ▶ Before pressing play, set the volume to the lowest setting.
- ▶ Start playback and increase the volume to a comfortable level.

## **4.2. Operational Safety**

Please read this section carefully and follow all instructions given. The instructions will help you to operate the notebook reliably and increase its service life.

### **Liquids penetrating the device may impair the electrical safety of the product.**

- ▶ Avoid exposing the device to water droplets or spray and do not place anything containing water, e.g. vases, on or near the device.
- ▶ Do not pour any fluids into the device.
- ▶ In order to avoid any damage to the device, ensure that the plug contacts do not come into contact with water under any circumstances. If this should occur, it is imperative that the plug contacts are dried thoroughly before the device is used again.



## **CAUTION!**

### **Danger of electric shock!**

There is a risk of electric shock or fire if the mains adapter is open!

- ▶ Never open the housing of the device, the battery or the mains adapter!
- ▶ Never operate the device if the housing is open.
- ▶ Never tamper with the mains adapter or live parts!

---

**The slots and openings on the device are for ventilation purposes.**

- ▶ Do not cover these openings, as this could cause the device to overheat or even catch fire.
- ▶ Do not insert anything into the device through the slots and openings. This could result in an electric shock or even ignite a fire which will damage your device.

**Should the below occur, switch the device off immediately/ do not switch the device on, disconnect the mains plug and contact customer services if:**

- unusual noises can be heard coming from the mains adapter or the notebook, or you notice smoke rising from the notebook or mains adapter.
- the AC adapter or the attached power cable or plug is burnt or damaged.
- ▶ Replace faulty mains cables/mains adaptors only with original parts. These parts should not be repaired under any circumstances.
- the device housing is damaged or liquid has penetrated into the device.
- ▶ Have the device inspected by customer services. Otherwise, it may not be possible to operate the device safely. There may be a risk of electric shock!



**WARNING!**

**Risk of explosion!**

Risk of explosion from the rechargeable battery.

- ▶ Never throw the notebook into an open fire.

---

### 4.3. Never carry out repairs yourself



#### **CAUTION!**

#### **Risk of electric shock!**

There is a risk of electric shock if repairs are not carried out by qualified personnel!

- ▶ Never open the housing of the notebook, the battery or the mains adapter!
- ▶ In the event of a fault, please contact the Service Centre or an approved repair specialist.

### 4.4. Setup Location

- The notebook may only be used indoors (due to the use of 5 GHz Wi-Fi technology).
- Do not use the device in areas where there is a risk of explosion such as tank farms, fuel storage depots or areas in which solvents are processed. It is also not permitted to use this device in those areas where the air is polluted with fine particles (e.g. flour dust or sawdust).
- Keep your notebook and all connected devices away from moisture and avoid dust, heat and direct sunlight. Non-compliance with these instructions can lead to faults or damage to the notebook.
- Do not use the notebook outdoors because external elements, such as rain, snow, etc., could damage it.
- Set up and operate all components on a stable, level and vibration-free surface to prevent the notebook from falling down.
- Maintain a distance of at least one metre from sources of high-frequency and magnetic interference (TV sets, speakers, mobile phones, DECT telephones, etc.) in order to avoid malfunctions and data loss.

- 
- Do not operate the notebook or power adaptor for long periods on your lap or any other body part as the heat dissipation on the underside can result in uncomfortable overheating.
  - This device is not suitable for use with VDU workstations.

#### **4.5. Environmental Requirements**

- The notebook is most reliably operated at an ambient temperature between 5 °C (+41 °F) and 30 °C (+86 °F) and at a relative humidity between 20% and 80% (without condensation).
- When switched off, the notebook can be stored for up to four weeks at temperatures between 0 °C (+32 °F) and 60 °C (+140 °F). In the event of storage for a longer period, the notebook can be stored between 0 °C (+32 °F) and 25 °C (+77 °F), although storage at 20 °C (+68 °F) ± 5 °C (+41 °F) is recommended.
- During a thunderstorm, unplug the AC adapter from the wall outlet. For extra safety, we recommend using an overvoltage protection device to prevent the notebook from sustaining damage as a result of power surges or lightning strikes.



#### **NOTICE!**

#### **Risk of damage!**

Large changes in temperature or fluctuations in humidity can cause moisture build up within the notebook due to condensation. This can cause an electrical short circuit.

- ▶ After transporting the notebook, wait until the device has reached room temperature before switching it on.

---

## 4.6. Power Supply



### **CAUTION!**

#### **Risk of electrical shock!**

There are live components inside this AC adapter. In the event of an unintentional short circuit of this AC adapter, there is a risk of electrical shock or fire!

- ▶ Do not open the housing of the AC adapter.
  - ▶ Do not cover the mains adapter.
  - ▶ Never touch the mains adapter with wet hands.
- The socket outlet must always be close to the notebook and easily accessible.
  - To disconnect the power supply from your notebook (via the AC adapter), switch off the power point and pull the mains plug from the power outlet. Do not pull on the cable to avoid damage. As long as the power adapter is connected to the mains, it will always consume a small amount of power.
  - Plug the notebook's AC adapter into AC 100 – 240 V~ 50/60 Hz earthed sockets only. If you are not sure about the power supply at the set-up location, please ask your electricity supplier.
  - For extra safety, we recommend using an overvoltage protection device (surge protector) to prevent your notebook from sustaining damage as a result of power surges or lightning strikes.
  - The only devices which may be connected to the device are those which meet the requirements defined in the safety standard for audio, video or information technology equipment.



## **NOTICE!**

### **Risk of damage!**

Unsuitable mains adapters may cause damage to the product.

- ▶ Only use the mains adapter supplied in order to charge the device.

## **4.7. Notes on the Battery**



## **WARNING!**

### **Risk of explosion!**

There is a risk of explosion if the battery is replaced incorrectly.

- ▶ Do not heat up the battery to a temperature greater than the maximum ambient temperature stated.
- ▶ Never open the battery.
- ▶ Do not throw the battery into an open fire.
- ▶ Do not short-circuit the battery.
- ▶ Only replace with the same type of battery or with a similar type recommended by the manufacturer.
- ▶ Dispose of used batteries in accordance with the information provided by the manufacturer

To extend your battery's performance and lifespan and ensure safe operation, you should also observe the guidelines below:

- Avoid dirt and contact with electrically conductive materials or chemical substances and cleaning agents.
- Use only the supplied AC adapter to charge the battery. Make sure (via the notebook display or acoustic signal) that the battery is fully discharged before charging it again.
- Do not remove the battery while the notebook is switched on or data may be lost.
- Take care when storing the battery and when using the notebook that the contacts on the battery and the notebook are not soiled or damaged. This could cause malfunctions.

- 
- Ensure the notebook is switched off before replacing the battery.

## **4.8. Cabling**

- Position the cables so that they cannot be stepped on or might cause a risk for tripping.
- To avoid damaging the cables, do not place any objects on them.
- Do not connect peripheral devices – such as keyboards, mouse and monitor, etc. – when the notebook is switched on to avoid damage to the notebook or the devices. Some devices may also be connected while the computer is running. This is generally the case for devices with a USB connection. In all cases, observe the relevant operating instructions.
- Maintain a distance of at least one metre from sources of high-frequency and magnetic interference (TV sets, speakers, mobile phones, DECT telephones, etc.) in order to avoid malfunctions and data loss.
- Please note that only shielded cables that are shorter than 3 metres may be connected to the external interfaces of this notebook.
- Do not exchange the supplied cable for another one. Use only the supplied cable as this cable has been extensively tested in our laboratory.
- In addition, when connecting your peripherals only use the connecting cables supplied with those devices.
- Ensure that all connection cables are connected to their corresponding peripheral device to avoid any interference radiation.
- Remove any unnecessary cables from your notebook to avoid possible interference.



---

## 4.9. Information about the Touchpad



### **NOTICE!**

#### **Risk of damage!**

The touchpad is a highly sensitive input device and it will respond to a light touch and minimal pressure.

- ▶ Never use undue force to operate the touchpad as this could damage or destroy it.

The touchpad is operated with the thumb or another finger and reacts to the energy given out by the skin. Dust or grease on the touchpad can affect its sensitivity.

- Do not use pens or other objects as these can damage your touchpad.
- Remove the dust or grease from the surface of the touchpad with a soft, dry and lint-free cloth.

## 4.10. Protecting the Display

The display is the most sensitive component part of the device as it consists of thin glass.

### **The display can break if subjected to too much stress.**

- Do not allow any objects to drop onto the display.
- Do not place any objects on the display.
- Do not scratch the display with your fingernails or hard objects.
- Never lift the notebook up by the display as this could break the hinges.
- Do not fold the display back by an angle of more than 130°. Exceeding this value may damage the housing or the device. Always hold the display firmly by the middle when folding it back, adjusting the position and closing it.
- If the screen breaks, there is a danger of injury. If this happens, pick up the shattered pieces wearing protective gloves and send them to your service centre for professional disposal. Finally, wash your hands with soap, as the pieces may have

---

been contaminated with chemicals.

- Avoid contact between the display and hard objects (e.g. buttons, wristwatch).

### 4.11. Data backup



Back up your data to external storage media before each update. We do not accept any liability for claims for compensation arising from loss of data or any consequential loss or damage.

### 4.12. Ergonomics



Avoid dazzle, reflections and a light-dark contrast that is too strong in order to protect your eyes.

The notebook should never be placed next to a window because this is the brightest part of the room in daylight. This brightness can make it more difficult for the eyes to adjust to the darker display. The notebook should always be positioned so that the direction of vision is parallel to the window front.

Setting up the notebook with your back to the window is incorrect as reflections from the bright window on the screen will then be unavoidable. A position looking onto the window is also incorrect as the contrast between the dark screen and the bright daylight can cause problems for the eyes to adjust and result in problems.

The parallel line of vision should also be maintained in relation to artificial lighting equipment.

In other words, the same criteria and principles apply where the workspace is illuminated with artificial light. Where space restrictions make it impossible to set up the screen as described, then correct positioning (rotating, tilting) of the notebook/screen can prevent dazzling, reflections and excessive bright-dark contrast, etc. In many cases, an improvement can also be achieved by using slats or vertical blinds on the windows, partition walls or by changing the artificial lighting equipment.



Take regular breaks when working at your notebook to prevent tenseness and fatigue.

Sitting for a long time without changing position can be uncomfortable. Correct posture is very important for minimising the risks of physical problems or damage.

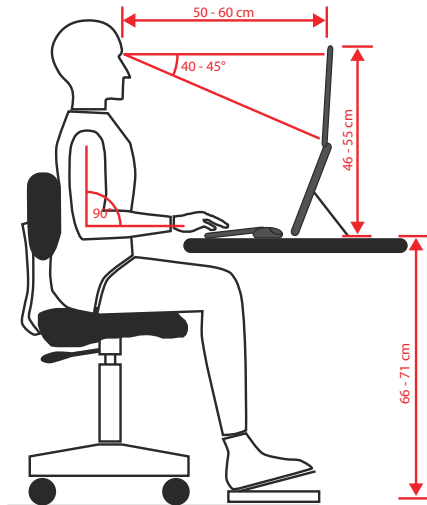

- **In general** – change your position frequently (around every 20-30 minutes) and take regular breaks to avoid tiredness.
- **Back** – when sitting at your workstation, your back must be supported by your chair's backrest, which must be upright or angled slightly back.
- **Arms** – your arms and elbows should be relaxed and loose. Your elbows should be close to your body. Hold your forearms and hands roughly parallel to the floor.
- **Wrists** – when working with the keyboard, mouse or trackball, your wrists should be stretched out and not bent at an angle of more than 10°, where possible. Make sure that your wrists are not resting on the table edge itself.
- **Legs** – your thighs should be horizontal or angled slightly down. Your lower legs should form an angle with your thighs of approximately 90°. Your feet should be resting flat on the floor. Use a foot rest if you need one, but first make sure that your seat height has been adjusted correctly.
- **Head** – your head should be upright or bent very slightly forward. Do not work with your head or upper body twisted.  
As you work, the top edge of the monitor should be at eye level or very slightly lower.  
The distance between the monitor and the person viewing it depends on individual requirements. Distances between 50 and 70cm are commonly used.

---

## 5. Included with your Notebook



### **Risk of suffocation!**

Packaging material is not a toy!

There is a risk of suffocation if plastic packaging is swallowed or used inappropriately!

- ▶ Keep packaging material, e.g. plastic film or bags, away from children.
- ▶ Check your purchase to ensure all items are included and contact us within 14 days of purchase if anything is missing.
- ▶ If there is any damage, please also contact our Service Department.

Please check that the contents are complete and notify us within 7 days of purchase if any of the following components are missing:

- notebook
- Battery
- AC adapter with power cord
- Documentation

## 6. Unpacking

- ▶ Choose a suitable place to set up the device before unpacking it.
- ▶ Remove all the packaging material.
- ▶ Please keep the packaging material in a safe place and only use this to transport the notebook.



The surfaces of the device are covered in protective film to prevent scratching during production and transport. Remove the film once the device has been set up properly and before you use it.

---

# 7. Views and description of the controls

## 7.1. Open Notebook

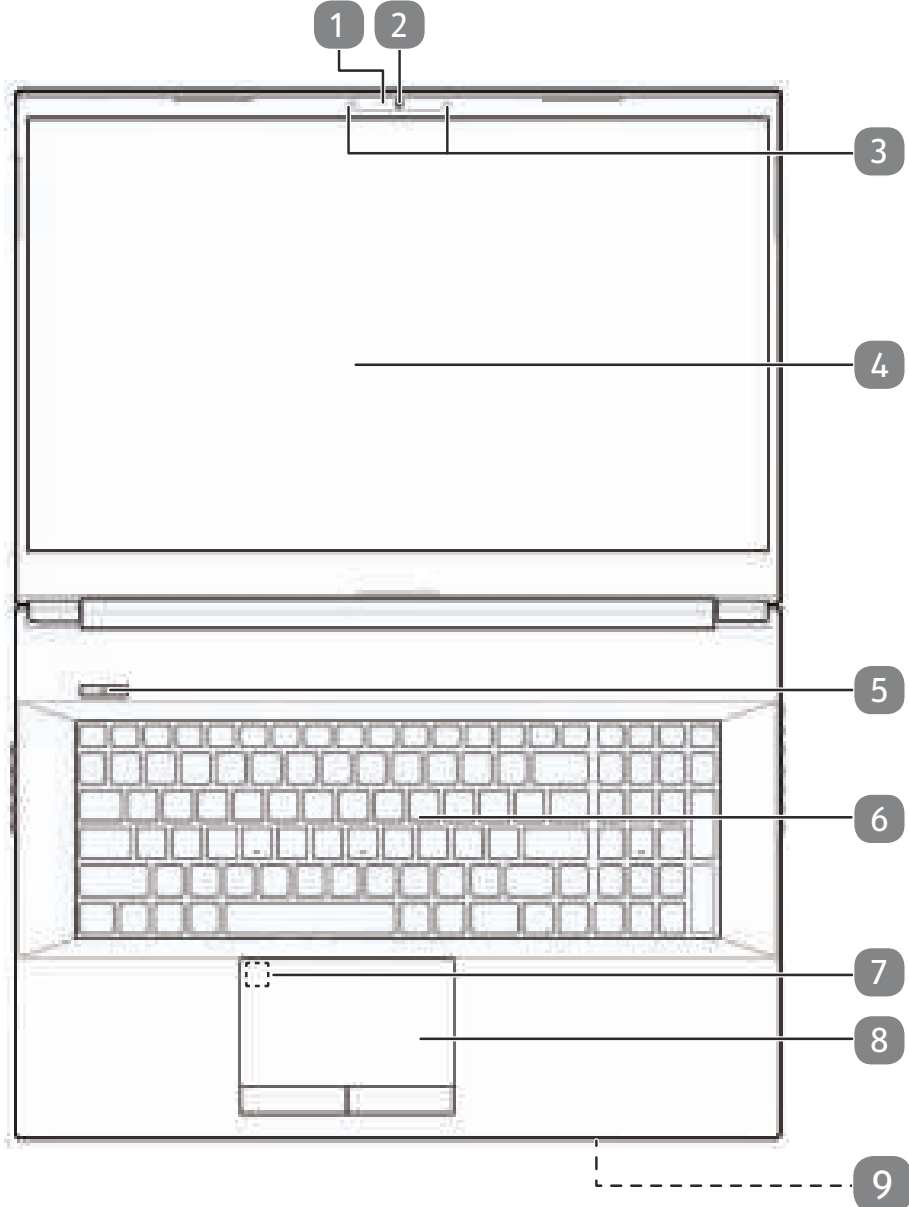

(similar picture)

- 
- 1 Microphones
  - 2 Webcam
  - 3 LED Webcam
  - 4 Display
  - 5 ON/OFF switch
  - 6 Keyboard
  - 7 Fingerprint Sensor (optional)
  - 8 Touchpad
  - 9 Operating and Status LEDs

## 7.2. Rear Side - Version 1

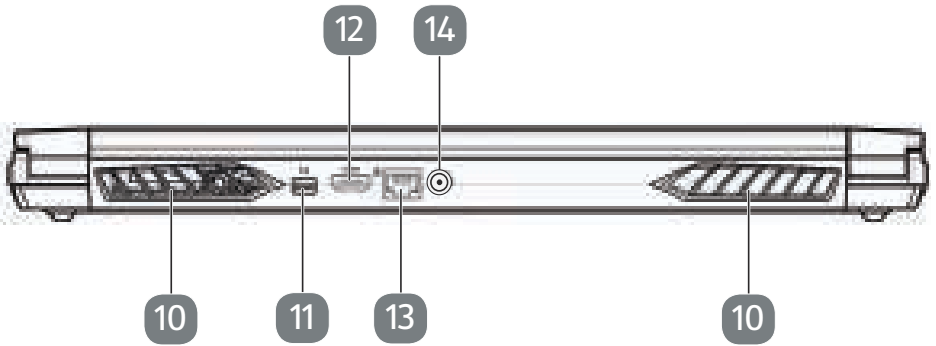

(similar picture)

- 10 Ventilation Openings
- 11 Mini DisplayPort
- 12 HDMI Connector
- 13 LAN Port (RJ-45)
- 14 Power Supply (DC In)

---

### 7.3. Rear Side - Version 2

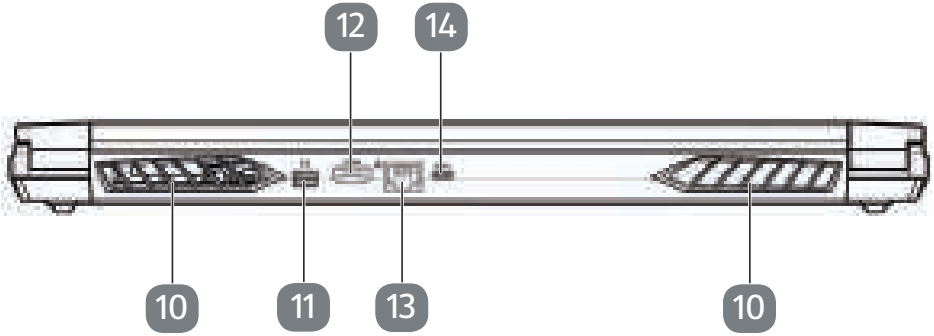

(similar picture)

- 10** Ventilation Openings
- 11** Mini DisplayPort
- 12** HDMI Connector
- 13** LAN Port (RJ-45)
- 14** USB 3.2 port (type C) with DisplayPort function  
(only with corresponding adapter, not supplied)

### 7.4. Left Side - Version 1

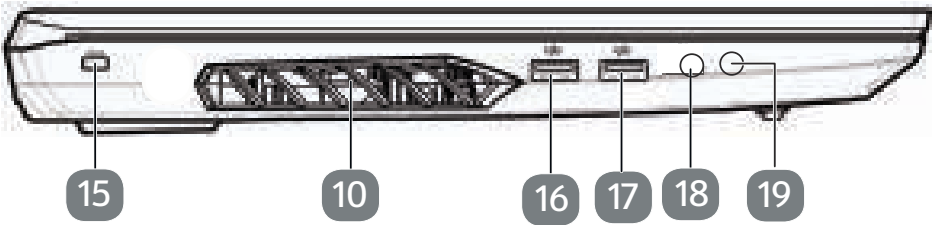

(similar picture)

- 10** Ventilation Openings
- 15** Kensington® Lock
- 16** USB 3.2 Gen1 Port (Type A)
- 17** USB 2.0 Port (Type A)
- 18** Microphone
- 19** Audio combi connection (mic in, headphones) (CTIA-Standard)

---

## 7.5. Left Side - Version 2

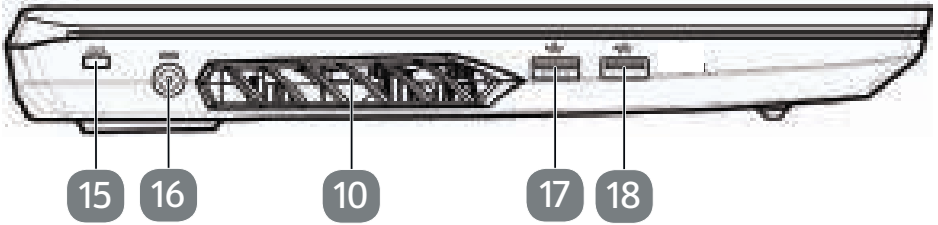

(similar picture)

- 10 Ventilation Openings
- 15 Kensington®Lock
- 16 Power Supply (DC In)
- 17 USB 3.2 Gen1 Port (Type A)
- 18 USB 3.2 Gen2 Port (Type A)

## 7.6. Right Side - Version 1

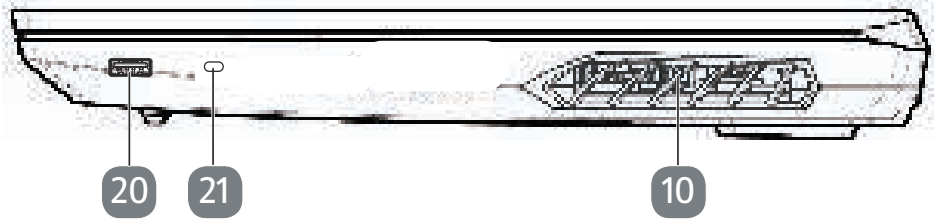

(similar picture)

- 10 Ventilation Openings
- 20 USB 3.2 Gen1 Port (Type A)
- 21 USB 3.2 Gen2 Port (Type C)



## 7.7. Right Side - Version 2

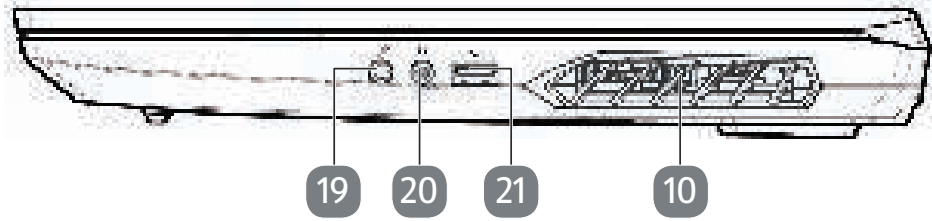

(similar picture)

- 10 Ventilation Openings
- 19 Microphone
- 20 Audio combi connection (mic in, headphones) (CTIA-Standard)
- 21 USB 2.0 Port (Type A)

## 7.8. Bottom View

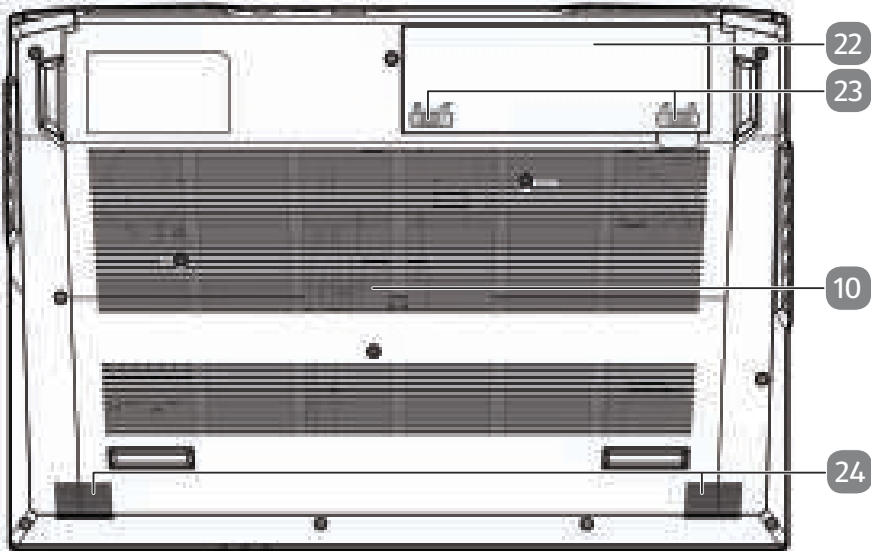

(similar picture)

- 10 Ventilation Openings
- 22 Battery Compartment
- 23 unlocking/locking the battery compartment cover
- 24 Stereo Speakers

---

## Operating and Status LEDs

The system displays power supply status and operating modes via LEDs. The operating lights also light up during notebook activity:



### Access Indicator

This LED lights or flashes when the notebook is accessing the hard disk.



### Airplane Mode

This indicator lights up when the airplane mode is activated.



### Battery LED

This indicator lights up when the battery is charging.

This indicator lights up green when the battery is fully charged.

The indicator flashes orange when the charge level of the battery is low and needs to be charged.



### Operating Indicator

This indicator lights up orange when the power adapter is connected.

The indicator lights up green when the device is switched on.

The indicator flashes green when the device is in energy-saving mode.

## 8. Power Supply

### 8.1. On/Off Switch

- ▶ Open the notebook and hold the on/off switch down briefly to switch the notebook on or off.



If it is no longer possible to switch off the notebook via the software, keep the On/Off switch pressed down for about 10 seconds.

Do not switch your notebook off while the hard drive is being accessed. Otherwise data may be lost. To protect the hard drive, you should always wait for 5 seconds after switching off the notebook before switching it back on again.

---

## 9. Preparation for Starting-Up

To operate your notebook safely and ensure a long service life, you have to read the “Operational Safety” chapter at the beginning of this manual. All operating software is already fully preinstalled on the notebook so there is no need for you to install any more drivers and you can get started right away.

- ▶ Before starting, insert the battery by placing it into the compartment until it clicks into place. Be sure to fasten the battery compartment to prevent the battery falling out.
- ▶ Connect the supplied AC adapter to the notebook. Next, connect the power cable to the adapter and then plug it into a power outlet.
- ▶ Open up the display to the desired position using your thumb and forefinger. The display should not be folded back by more than 130°. Always hold the display firmly by the middle when folding it back, adjusting the position and closing it. Failure to do so may damage the display. Never use force to open the display.



When first operating your notebook please ensure that the battery is inserted and the AC adapter is connected.

- ▶ Switch the notebook on by pressing the on/off switch. The notebook will now start and run through various installation steps.

The operating system cannot be used unless you agree to the terms and conditions of use during the installation process. Have the information ready for access to Wi-Fi or your email inbox in case you wish to set this up now.

The loading process of the operating system takes a little longer during the initial setup. Once all the necessary data has been entered, the operating system will be set up. The operating system is fully loaded once the Windows® start-up screen appears.



### **NOTICE!** **Loss of data!**

The initial installation may take a few minutes. Do not unplug the notebook from the power source or switch it off during the initial installation. This may adversely affect the installation.

- ▶ Do not switch off the notebook until after the installation has been completed successfully and the startup screen appears.

---

## 9.1. Starting the Notebook

- ▶ Open up the display as described above and press the on/off switch.
- ▶ Follow the instructions on the screen. Step by step instructions will guide you through the process to be followed.

The welcome procedure takes you through several screens and dialogues.

- ▶ Select your desired language and then the corresponding country settings.
- ▶ Connect to the Internet if you have a properly-equipped Internet connection.

If you choose to skip this point, you can connect to the Internet later via the Windows® interface.

If you have already set up an Internet connection, you can now log in to your notebook using a Microsoft account.

The Microsoft Store allows you to purchase new apps or update previously installed apps. If you log in on a local account, you can set up a Microsoft account later at any time.

### Licence Agreement

Please read through the licence agreement carefully. It provides important legal information about the use of your software product. To view the text in full, you must slide the scroll bar downwards using the mouse until you reach the end of the document. You accept the licence agreement by checking **Accept**. Only this entitles you to use the product in accordance with the terms and conditions.

The following animated windows simply contain information about using the new Windows® operating system. No entries of any kind may be made during the animation. The Windows® interface appears after the login process.



In the first few days following the initial installation, Windows® may update and configure data (e.g. with new updates) which can result in delays in the notebook shutting down and starting up. For this reason, do not switch the notebook off prematurely. This may adversely affect the installation.

## 10. AC Power

Your notebook comes with a universal AC power supply for alternating current which automatically adapts to the available power source. The following values are supported: AC 100 – 240 V~ 50/60 Hz. Observe the safety information concerning the power supply.

The adapter supplies the notebook with power and also charges the battery. Your battery will also be charged while you work on your notebook with the AC adapter connected. The AC adapter also consumes power when the notebook is not connected to it. You should therefore always remove the AC adapter plug from the wall outlet when it is not connected to the notebook.



Make sure that you only use the supplied mains adapter with this notebook.

## 11. Battery Mode



Batteries store electrical energy in their cells and then release it again as required. Please charge and discharge the new battery completely two or three times consecutively to ensure that it reaches its optimum performance!

### 11.1. General Handling of Rechargeable Batteries

When handling rechargeable batteries, it is important to ensure that they are correctly used and charged so that the capacity of the battery is fully utilised and its service life is maintained for as long as possible. The optimal charging temperature is approx. 20 °C . Please also take note of the safety instructions on “Safety Instructions“.

- ▶ Ensure that the rechargeable batteries are stored correctly if you are not using the device for a long period of time.
- ▶ Carry out a complete discharging and charging cycle once a month, then store the device with approx. 50% of the battery capacity. This will prevent the battery becoming full discharged and permanently damaged or no longer capable of being charged.
- ▶ The rechargeable battery should not be charged unattended.
- ▶ Do not position the rechargeable battery on sensitive or highly flammable materials during the charging process.
- ▶ Do not cover the notebook while charging the battery.

#### 11.1.1. Shipping Mode

The notebook is in secure transport mode after being unpacked; this prevents accidental switching on and discharging the battery.

- ▶ Before switching on for the first time, you must connect the AC adapter and wait around 8 seconds before activating the on/off switch.

#### 11.1.2. Inserting the Battery

- ▶ Insert the battery by sliding it into the compartment until it clicks into place. Be sure to fasten the battery compartment to prevent the battery falling out.

#### 11.1.3. Removing the Battery

- ▶ Ensure that the notebook is switched off and that it is not connected to a power outlet.
- ▶ Turn the notebook upside down
- ▶ Unlock the battery by pushing the lock outwards into the  position.

- 
- ▶ Hold the lock in the open position and remove the battery.



### **NOTICE!**

#### **Risk of damage!**

Damaged or dirty contacts on the battery and notebook can result in faults.

- ▶ When storing the battery and when using the notebook, make sure that the contacts on the battery and the notebook do not become dirty or damaged.



### **NOTICE!**

#### **Loss of data!**

A sudden power failure may result in the loss of data.

- ▶ Do not remove the battery while the notebook is switched on or data may be lost.

#### **11.1.4. Charging the Battery**

The battery is charged using the AC adapter. When the AC adapter is connected, the battery charges automatically regardless of whether or not the notebook is switched on or not. A complete charge takes a few hours with the notebook switched off. With the notebook switched on, the charging process takes significantly longer.



The charging process is interrupted if the temperature gets too high. Left-click on the battery symbol in the taskbar to display the battery status, and, if necessary, use the **F1** key to open Windows Help.

#### **11.1.5. Discharging the Battery**

Operate the notebook on battery power until it turns itself off due to low battery charge.



### **NOTICE!**

#### **Loss of data!**

A sudden power failure may result in the loss of data.

- ▶ Be sure to save your open files promptly to prevent any data loss.

---

### 11.1.6. Battery life

The actual operating time varies depending on the configuration of the power-saving functions. Note: your notebook consumes more power when running certain applications.

The battery life will be reduced if the processor or graphics components of the notebook are used to capacity over an extended period of time. This can occur in the case of games with elaborate graphics, videos, music editing or graphics editing.



If you ignore the low battery warning, your notebook will shut down.

## 12. Power Management (Power Options)

Your notebook offers automatic and user selectable power-saving and energy functions that can be used to optimize battery life and reduce the overall operating costs.



If you need help with the power management of your notebook, press the **F1** key for Windows Help.

### 12.1. Energy Saving Tips

- Utilize the **Fn+F12** sleep mode keys to turn into power saving mode.
- Tune the settings in Power Options to optimise the computer's power management.
- Always disconnect the AC power cord or uninstall the battery pack or switch off the wall outlet if the computer would be left unused for a certain time to achieve zero energy consumption.

The power management feature allows the computer to initiate a lower-power or "Sleep" mode after a period of user inactivity.

To take advantage of these potential energy savings, the power management feature has been preset to behave in the following ways when the system is operating on AC power:

- Turn off the display after 10 minutes
- Initiate Sleep after 30 minutes

and when the system is operating on DC power:

- Turn off the display after 5 minutes
- Initiate Sleep after 15 minutes

The notebook exits Sleep when the On/Off button is pressed.

---

## 13. Display

### 13.1. Opening and Closing the Display

The special design of the display hinges keeps the display closed without the need for an additional catch.

- ▶ To open the notebook, fold the display up to the desired position using your thumb and forefinger.



#### **NOTICE!**

#### **Risk of damage!**

Forcibly opening up the screen may damage the notebook.

- ▶ Always hold the display firmly in the middle when folding it open, adjusting the position and closing it.
- ▶ Do not fold open the display by an angle of more than 130°.

The opening and closing of the display can be assigned different functions, e.g. power save, hibernate and shut down, via Settings -> System -> Mains operation and Power save.

### 13.2. Connecting an External Monitor

The Notebook has a Mini DisplayPort as well as an HDMI port for an external monitor.

- ▶ Shut down your Notebook correctly.
- ▶ Plug the external monitor's signal cable (not included) into the HDMI socket on the Notebook.

You can connect another monitor via the USB 3.2 port (type C) (optional) with DisplayPort function. Please note that you will need an appropriate adapter for this (not supplied).

- ▶ Connect the external monitor to the wall outlet and switch it on.
- ▶ Now switch your Notebook on.

### 13.3. Data Input

### 13.4. Keyboard

The double assignment of certain keys means that the range of functions available to you is the same as on a conventional Windows keyboard. Some functions are entered using the **Fn** key (standard on most notebooks).



### 13.4.1. Specific Keyboard Shortcuts

	Description
<b>Fn + F1</b>	<b>Touchpad</b> Switches the touchpad on and off.
<b>Fn + F2</b>	<b>Background lighting of the display</b> Turns off background lighting for the integrated display to save power. The lighting is turned back on by pressing any key.
<b>Fn + F3</b>	<b>Mute</b> Switches the sound on or off.
<b>Fn + F5</b>	<b>Volume down</b> Decreases the playback volume.
<b>Fn + F6</b>	<b>Volume up</b> Increases the playback volume.
<b>Fn + F7</b>	<b>Display</b> Switches the screen display between LCD, external display and duplicate display.
<b>Fn + F8</b>	<b>Brightness down</b> Reduces the brightness of the display.
<b>Fn + F9</b>	<b>Brightness up</b> Increases the brightness of the display.
<b>Fn + F10</b>	<b>Webcam</b> Enables or disables the webcam.
<b>Fn + F11</b>	<b>Airplane mode</b> Switches the airplane mode on or off.
<b>Fn + F12</b>	<b>Sleep</b> The notebook goes into power-saving mode.

### 13.5. Touchpad



#### **NOTICE!**

#### **Risk of damage!**

If unsuitable objects are used to control the device, this could permanently damage the touchpad.

- ▶ Do not use any sharp objects (e.g. a pen).

---

## 14. Sound System

### 14.1. External Audio Connections

Using the external connections provides you with an ideal opportunity to connect your Notebook to external devices.

The **Fn+F5** and **Fn+F6** keyboard shortcut enables you to adjust the volume.

You can change the settings by right-clicking on the speaker symbol in the taskbar.



#### **WARNING!**

#### **Impairment to hearing!**

Listening through earphones or headphones at excessive volume levels, as well as changes to the basic settings of the equaliser, drivers, software or operating system generates excessive acoustic pressure and can lead to damage or loss of hearing.

- ▶ Before pressing play, set the volume to the lowest setting.
- ▶ Start playback and increase the volume to a comfortable level.

## 15. Network Operation

### 15.1. Network Connection

Connect one end of a cable with a RJ45 connection (western jack) to your Notebook's network interface and the other to a different computer or hub/switch. You can find more details about the network in the Windows® help.

### 15.2. Wi-Fi (Wireless Network)

This function enables you to establish a network connection to a corresponding remote station. Please read about the necessary requirements. The Wi-Fi function is enabled and disabled via the Windows® menu and is activated by default.

#### 15.2.1. Restricted use

Always switch off the product in the following situations:

- in hospitals, clinics or other health centres and in all places in the immediate vicinity of medical equipment,
- in all places where there is a risk of explosion (e.g. petrol stations; in dusty environments, e.g. with metal dust),

- 
- in places where it is compulsory to switch off radio-controlled equipment, e.g. on major construction sites or in places where blasting operations are carried out.



## **WARNING!**

### **Danger from radio signals and electromagnetic radiation!**

Radio signals and electromagnetic radiation can affect the functionality of sensitive electronic devices, such as pacemakers or implanted cardioverter defibrillators.

- ▶ Keep the product at least 20 cm away from these devices, as radio signals and electromagnetic radiation may affect their functionality.



The radio waves emitted may cause interference to hearing aids.

### **15.2.2. Data security**

The manufacturer is not liable for data loss due to unsecured access by third parties.

Secure your WLAN network with suitable encryption so that third parties cannot access your data.

### **15.2.3. Requirements**

A so called Wi-Fi access point may be used as a remote station. A Wi-Fi access point is a radio transmitting device that communicates with your Notebook and controls access to the connected network.

Wi-Fi access points are frequently found in large offices, airports, train stations, universities or Internet cafés. They provide access to particular services and networks or to the Internet.

Access permissions are generally necessary and often result in usage charges. Access points often have built-in DSL modems. These so called routers establish the connection to the existing DSL Internet connection and the Wi-Fi.

A connection can also be established to another end device with Wi-Fi functionality without an access point. Without a router, however, the network is restricted to those devices directly connected to it.

If encryption is used for the transfer, the same procedure must be used for all devices. Encryption is a procedure to protect the network from unauthorised access.

---

The transfer speed can vary depending on the distance and the number of users accessing the remote station.

### 15.3. Bluetooth®

Bluetooth technology is used to wirelessly bridge short distances. Bluetooth devices transfer data via radio so that computers, mobile phones, printers, keyboards, mice and other devices can communicate with one another wirelessly. Bluetooth wireless technology has numerous possible applications. A few of them are listed below:

- Creating a wireless Internet connection using a mobile phone.
- Transferring files between computers or between a computer and another device.
- Printing using a Bluetooth printer.
- Using a Bluetooth keyboard and mouse.
- Connecting to a PAN (Personal Area Network).

The Bluetooth wireless technology data transfer speed can vary depending on the device or environmental factors. Data can be transferred through walls, jacket pockets and briefcases using a Bluetooth device. The transfer between Bluetooth devices occurs at the high frequency of 2.4 Gigahertz (GHz).



Do not operate the Bluetooth function in locations (e.g.: hospitals, aeroplanes, etc.) where there is sensitive equipment. Do not switch the device unless you are sure it will cause no interference.

### 15.4. Airplane Mode

In flight mode, all wireless connections (e.g. Wi-Fi, Bluetooth®) are disabled. The airplane mode is disabled by default to ensure that all wireless connections are available.

## 16. USB Port

The universal serial bus is a standard for connecting input devices, scanners and other peripherals. The USB 3.2 ports are fully backwards compatible.



Due to the arrangement of the contacts, the plug will only fit into the socket in one position (exception USB type C).

Ensure that the plug and the port fit together precisely in order to avoid any damage to the contacts. Where possible, always connect your USB devices to the same port that they were originally installed on. Otherwise they will be assigned a new ID and the drivers will need to be reinstalled.

---

## 17. Securing Your Notebook

### 17.1. Password Setting (Power-on)

You can protect your notebook against unauthorised use with a power-on password. On switching on the notebook, a password prompt will appear on the screen. The password is set up in the **UEFI configuraton**.



#### **NOTICE!**

#### **Risk of damage!**

Please note that changes should only be carried out here by very experienced users, as changes in the UEFI setting may have implications for the stable operation of the notebook.

- ▶ Keep your password in a safe place. If you forget your password, you have no way of deleting it. If this happens, contact your service centre.

You can also use the Windows® security options to protect your data against unauthorised access.

### 17.2. Kensington Security Lock

you can use a so called **Kensington security lock** to protect your notebook against theft. This security lock (complete with cable) is usually available as an accessory in specialist retailers.

To attach the security lock, wind the cable around a stationery object, e.g. a table leg. Plug the lock into the Kensington device and turn the key to lock it. Keep the key in a safe place.

### 17.3. Fingerprint Sensor (optional)

#### 17.3.1. Setting up the fingerprint sensor

- ▶ Open the Start menu and click/tap on **Settings** -> **Accounts** -> **Sign-in options**.
- ▶ Click/tap on the **Set up** button under the heading **Fingerprint** in the section **Windows Hello**.



If you have not yet created a PIN for the sign-in process, this needs to be created first.

- 
- ▶ In the welcome screen for Windows Hello, click/tap on the **Get started** button.
  - ▶ Enter your PIN in response to the next query.
  - ▶ Now scan the desired fingerprint.



The fingerprint needs to be read multiple times, follow the instructions on the screen for this purpose.

- ▶ Once the fingerprint has been successfully read, click/tap on the **Add another** button in the pop-up window to scan another fingerprint.
- ▶ Once all of the fingerprints have been read, click/tap on the **Close** button in the pop-up window to conclude the process.

### 17.3.2. Removing the fingerprints

- ▶ Open the Start menu and click/tap on **Settings** -> **Accounts** -> **Sign-in options**.
- ▶ Click/tap on the **Remove** button under the heading **Fingerprint** in the section **Windows Hello**.

## 18. Resetting the notebook to its Factory Settings

Depending on the features of your notebook, use either Cyberlink PowerRecover or the Windows system recovery options if your system fails to respond as normal and a system recovery becomes necessary.



### NOTICE!

#### Risk of damage!

A flat battery during the recovery process may lead to data loss or cause damage to the system.

- ▶ Always connect the mains adapter when restoring the system as the recovery process may take several hours.

---

## 18.1. System recovery with PowerRecover (optional)

In the event of problems with the installation or other software problems which make it necessary to reinstall the software, Windows® offers three options for reinstalling Windows® on your notebook.

First ensure that you have backed up all important data and programs.

### 18.1.1. Start System Restore

- ▶ Restart the device and press the F11 button during the boot process to start **PowerRecover**.

or

- ▶ Click on the **PowerRecover** app in the Start menu to start the program.

You will be offered the following options:

- **Create driver and tool rescue media**

The drivers and tools will be saved to a storage medium.

- **Create driver and tool rescue media**

Create a support disc

- **Create driver and tool rescue USB disk**

Create a support USB storage medium

- **Update your PC, without damaging your data**

Updates the device with the help of the Windows recovery options.

- **Keep my files**

All apps and settings will be deleted, while personal data will be retained.

- **Remove everything**

All data, apps and settings will be deleted.

- **Restore**

The device will be restarted and reset to the factory settings.

- **Reset to HDD - user data not saved**

All data on the device will be permanently deleted.

The factory settings will be restored.

- **Reset to HDD - user data saved**

The factory settings will be restored and all user data under **C:\USERS** will be backed up.

- ▶ Click on **Next** and follow the on-screen instructions to restore the factory settings.



If your system does not start the PowerRecover program when the **F11** button is pressed then it uses the Windows Recovery options; in this case, read the information in the chapter “System restore with Windows Recovery Options”.

---

## 18.2. System Restore with Windows Recovery Options

If you experience problems with your device, you can refresh or reset it. Windows is reinstalled when you refresh your device. Your personal files and settings are retained.

Windows is also reinstalled when you reset your device. However, your files, settings and apps – except for the apps pre-installed on the device – are deleted.



If your notebook does not start properly three times in a row, the Windows recovery menu automatically appears.

### 18.2.1. How to Refresh your Notebook

- ▶ Open the start menu.
- ▶ Select the **Settings** app from the list.
- ▶ Tap or click on **Update & Security**.
- ▶ Tap or click on the menu option **Recovery**.
- ▶ Tap or click on **Get started**.
- ▶ A dialogue box will now open, select the recovery option **Keep my files** to refresh your notebook.

### 18.2.2. How to Reset your Notebook

- ▶ Open the start menu.
- ▶ Select the **Settings** app from the list.
- ▶ Tap or click on **Update & Security**.
- ▶ Tap or click on the menu option **Recovery**.
- ▶ Tap or click on **Get started**.
- ▶ A dialogue box will now open, select the recovery option **Remove everything** to completely reinstall Windows.



#### **NOTICE!**

#### **Loss of data!**

All the data stored on your notebook will be deleted as a result of resetting it.

- ▶ Back up your data before resetting the notebook.





Always perform any type of recovery using AC power.

If you have forgotten the Windows password for your device, you can also restore the notebook from the login screen after rebooting the device.

To do this, hold down the Shift key while on the login screen and then select **Power** (⏻) > **Restart** in the bottom right. After rebooting the device, select **Troubleshoot** > **Reset this PC**.

## 19. UEFI Configuration

The UEFI configuration (basic hardware configuration of your system) provides you with a number of options for the configuration and operation of your notebook. For example, you can modify the operating mode for interfaces, security features or power supply management. The notebook has already been configured by the manufacturer to ensure optimum operation.



### **NOTICE!**

#### **Loss of data!**

The notebook has already been configured by the manufacturer to ensure optimum operation. Modifications may affect the stable and safe operation of the system.

- ▶ Changes must only be carried out by specialists or very experienced users.

### 19.1. Executing the UEFI Configuration

You can only run the configuration program upon system startup. If the notebook has already started up, switch it off and restart it.

- ▶ Press the **F2** key to run the **UEFI configuration**.

## 20. FAQs – Frequently Asked Questions

### **How do I activate Windows®?**

- Windows® is activated automatically as soon as an Internet connection is established.

### **The time is incorrect.**

- ▶ Click with the right mouse button on the clock in the bottom right corner of your screen and then click on “Adjust date/time”.
- ▶ You can then change the time and also, if necessary, the time zone in the window that opens.

---

### **When is restoring factory settings recommended?**

- This method should only be selected as a last resort. Read about the alternatives in the **System recovery** section.

### **How do I perform a data backup?**

- Back up your data on external media. If you need help to back up your data, press the **F1** key for Windows Help.

### **Why do I need to reinstall my USB device even though I have already done it?**

- If the device is not operated on the same USB port as the one it was installed in, it automatically receives a new identifier. The operating system then treats it like a new device and tries to reinstall it.
- Use the installed driver or connect the device to the port on which it was originally installed.

### **The notebook will not switch on.**

- ▶ If the notebook is in battery mode, connect the notebook to the AC adapter and check that the battery is charged or being charged.
- ▶ If you are already operating the notebook using the AC adapter, disconnect the adapter plug from the outlet and connect an electrical appliance such as a lamp to the same outlet to test it. If the lamp does not work either, seek the advice of an electrician.

### **The screen is black.**

- This fault can have various causes:
  - The operating light (on/off switch) does not light up and the Notebook is in hibernation.

#### **Solution:**

Press the on/off switch.

- The background lighting has been disabled using the **Fn + F2** keyboard shortcut.

#### **Solution:**

Reactivate the background lighting by pressing any key.

### **The Notebook turns itself off during operation.**

- ▶ The battery may be fully discharged. Plug the Notebook in using the AC adapter and charge the battery.

### **The Notebook cannot be switched on.**

- ▶ If you are running the Notebook on battery, check that it has been inserted correctly and is fully charged.

### **The WLAN/Bluetooth connections do not work.**

- ▶ Check whether airplane mode is disabled.

### **The touchpad is not working.**

- ▶ To activate the touchpad, press the **Fn+F1** keyboard shortcut.

### **Apps (e.g. the weather app) cannot be displayed as live tiles.**

- ▶ Check the date, time zone and time.

---

## Problem recognising an additional hard drive

If you add an additional hard drive to your device, the drive may not be immediately visible under Windows. If this is the case, proceed as follows:

- ▶ Right click on the **Start button**.
- ▶ Then left click on **Disk Management** and confirm the window that now opens with **OK**.
- ▶ Maximise the next window so that it is easier to work in it.

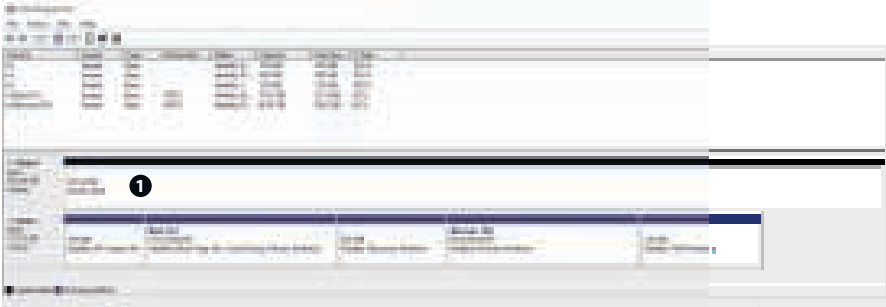

In the lower part of the window ❶ you can now see the additional hard drive.

- ▶ Click with the right mouse button in the area highlighted above ❶.
- ▶ Select the first option shown and confirm your selection by clicking the left mouse button.
- ▶ Now keep clicking on **Next** until **Finish** appears and click on it to confirm.

The hard drive will be visible in Windows Explorer and available for use after a few seconds.



For questions about the operating system, please use the system's built-in help function by pressing the **F1** key or go to [www.microsoft.com](http://www.microsoft.com).

## 21. Customer Service

### 21.1. What To Do in Case of Hardware Problems

Malfunctions can sometimes have quite trivial causes, but they may also be the result of defective components. We have included a brief troubleshooting guide below which may help to solve any problems.

If these tips don't do the trick, then we'll be more than pleased to help you out. Just give us a call!

### 21.2. Find the Cause

Start by carefully checking all the cable connections. If the notebook is connected to peripheral devices, check all the cable connections here too.

---

## 21.3. Do You Need More Help?

You've checked through the suggestions in the previous section and you're still having problems with your device? Then call our hotline or contact us at [www.medion.com](http://www.medion.com). We'll be glad to help you.

Before contacting your technology centre, however, prepare the following information:

- Have you made any upgrades or modifications to the initial configuration?
- What is the model number of your notebook? (model number to be found on the rating plate of your product)
- What peripheral devices do you use?
- What messages, if any, appear?
- What software were you using when the problem occurred?
- What steps have you already taken to try and rectify the problem?

## 21.4. Driver Support

The system has been thoroughly and successfully tested with the installed drivers in our test laboratory. It is normal in the computer sector, however, for the drivers to need updating from time to time. This is because there may be compatibility problems with other components (programs, devices) which have not yet been tested.



For critical or security-related updates, the drivers are loaded and installed automatically when the device is connected to the internet. So-called optional driver updates can be loaded and installed via the Windows Update function.

The current drivers are available on our homepage at [www.medion.com](http://www.medion.com). Please use the service address for the country where the device was purchased.

## 21.5. Transport

Please note the following information if you wish to transport the Notebook:

- ▶ Switch the notebook off.
- ▶ After transporting the notebook, wait until the appliance has reached room temperature before switching it on. Large changes in temperature or fluctuations in humidity can cause moisture build-up within the notebook due to condensation. This can cause an electrical short circuit.
- ▶ Always use a notebook carrying case to protect the notebook from dirt, moisture, vibrations and scratches.
- ▶ Always use the original cardboard packaging to ship your notebook and obtain advice on this from your carrier.
- ▶ Always charge your battery fully before embarking on longer trips and do not forget to take along your AC adapter.

- 
- ▶ Find out about the power and communication options available in your destination before travelling.
  - ▶ Where necessary, purchase the required power adapter before departure.
  - ▶ When shipping the notebook, pack the battery separately in the cardboard packaging.
  - ▶ When going through the hand luggage check at the airport it is recommended that you send the notebook and all magnetic storage media (e. g. external hard drives) through the x-ray facility (the device that scans your bags). Avoid the magnetic sensor (the structure that you walk through) or the magnetic hand scanner (the manual device used by security personnel) as this may destroy your data, among other things.

## 21.6. Cleaning and Maintenance



### **WARNING!**

#### **Danger of electric shock!**

There is a risk of death as a result of electric shock if the housing is open and if parts inside the device are touched!

- ▶ Do not open the housing of the notebook. It does not contain any parts requiring maintenance. Always unplug the device and disconnect all cables before cleaning!

You can increase the lifespan of your notebook with the following measures:

- ▶ Only use a damp, lint-free cloth to clean the notebook.
- ▶ Do not use solvents, corrosive or aerosol-based detergents to clean the device.
- ▶ Use special cleaning products for the display and the touchpad (e.g. glass cleaner).
- ▶ Under no circumstances must liquids penetrate inside the device as this may cause damage.
- ▶ Do not expose the screen to strong sunlight or ultraviolet light.



### **NOTICE!**

#### **Risk of damage!**

To avoid damaging the device, never allow the plug contacts to come into contact with water.

- ▶ If this nevertheless happens, it is essential that the plug contacts are rubbed dry before using the device again.

---

## 21.7. Storage when not in use

Store the notebook in a cool, dry place if you are not going to use it for an extended period of time and make sure that it is protected from dust and extremes of temperature.

- ▶ Remove the battery from the device if you are not going to use it for an extended period of time and store the battery in a cool, dry place.
- ▶ Remove all media from the USB slots.
- ▶ Remove all cables and connected peripheral devices.



When the notebook is not in use, we recommend storing it in a bag to protect it from dust and dirt.

### 21.7.1. Battery Protection



#### NOTICE!

#### Loss of data!

Unintentional or random changes to UEFI settings may affect the stable and safe operation of the system.

- ▶ Changes must only be carried out by specialists or very experienced users.

If you cannot use your laptop for a longer period of time (e.g. you go on holiday) activate the automatic battery protection manually in your device's UEFI. This protects your battery from fully discharging.

- ▶ In the UEFI you will find the **Shipping Mode** option under the **Exit** menu option.
- ▶ Select the **Shipping Mode** option with the arrow keys.
- ▶ Confirm the selection with **Enter**.
- ▶ The notebook closes down.
- ▶ Unplug the notebook from the mains.
- ▶ Keep the on/off switch pressed briefly.

The notebook is now in transport mode. Read more about this in the „Transport Mode“ chapter.

## 22. Upgrading/Modifying and Repair

Upgrades and modifications to your notebook should only be carried out by qualified specialists. If you do not have the necessary qualifications, have the work carried out by a qualified service technician. Please contact your customer service department if you have technical problems with your notebook.

If a repair must be carried out, please contact only our authorised service partners.

---

## 22.1. Notes for Service Technicians

- ▶ Only service technicians may open up the notebook housing or upgrade or modify your notebook.
- ▶ Use only original replacement parts.
- ▶ Before opening the housing, disconnect all power and connecting cables. If the notebook is not disconnected from the power supply before being opened, there is a risk that components could be damaged.
- ▶ Internal components of the notebook may be damaged by electrostatic discharge (ESD). Carry out repairs, as well as system enhancements or modifications, at an ESD workplace. If such a workplace is not available, wear an antistatic cuff or ensure you are touching an earthed, metallic object. We will charge for any repairs to damage caused by incorrect handling.

## 23. Disposal



### PACKAGING

The product has been packaged to protect it from damage in transit. The packaging is made of materials that can be recycled in an environmentally friendly manner.



### DEVICE

All old appliances marked with the symbol illustrated must not be disposed of in normal household rubbish.

In accordance with Directive 2012/19/EU, the device must be properly disposed of at the end of its service life.

This involves separating the materials in the device for the purpose of recycling and minimising the environmental impact.

Take old devices to a collection point for electrical scrap or a recycling centre. Before doing so, remove the batteries from the device and take them to a separate collection point for used batteries.

Contact your local waste disposal company or your local authority for more information on this subject.



### BATTERIES

Do not dispose of used batteries with household rubbish. Batteries must be disposed of correctly. Retailers that sell batteries and local collection points provide containers in which you can dispose of them. Contact your local waste disposal company or your local authority for more information.

In connection with the sale of batteries or the supply of equipment containing batteries, we are obliged to draw your attention to the following: As the end user, you are legally required to return used batteries. The crossed-out wheeled bin symbol means that the battery must not be disposed of with household rubbish.

---

## 24. Information on Display Errors

### 24.1. European EN ISO 9241-307 Class II Standard

Due to the very high number of transistors and the associated extremely complex manufacturing processes used, occasionally one or more pixels can fail or become incorrectly controlled.

In the past, there were a number of approaches for defining the permitted number of pixel defects. However, these approaches were mostly very complicated and varied from one manufacturer to the next. When handling warranty issues for all of its display products, MEDION therefore adheres to the strict and transparent requirements of the standard **EN ISO 9241-307, Class II**; which has been briefly summarised below.

The **EN ISO 9241-307** standard defines, amongst other things, the generally applicable guidelines relating to pixel defects. Pixel defects are categorised into four fault classes and three defect types. Every individual pixel consists of three sub-pixels, each of which is assigned a basic colour (red, green, blue).

#### Pixel structure

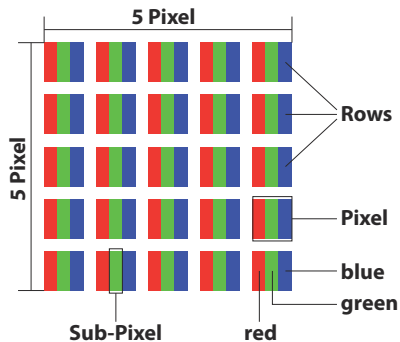

#### Pixel defect types:

- Type 1:  
permanently illuminated pixel (bright, white dot) even when not activated. A white pixel occurs due to the illumination of all three sub-pixels.
- Type 2:  
non-illuminated pixel (dark, black dot) even when activated.
- Type 3:  
abnormal or faulty red, green or blue sub-pixel (e.g. permanently illuminated at half brightness, one colour not illuminated, flashing or flickering but not type 1 or 2)

Supplement: Type 3 cluster (= failure of two or more sub-pixels within a 5 x 5 pixel block). A cluster is a field of 5 x 5 pixels (15 x 5 sub-pixels).



## EN ISO 9241-307, error class II

Resolution	Type 1	Type 2	Type 3	Cluster Type 1, type 2	Cluster Type 3
1024 x 768	2	2	4	0	2
1280 x 800	3	3	6	0	3
1280 x 854	3	3	6	0	3
1280 x 1024	3	3	7	0	3
1366 x 768	3	3	7	0	3
1400 x 1050	3	3	8	0	3
1600 x 900	3	3	8	0	3
1920 x 1080	4	4	9	0	3
1920 x 1200	4	4	9	0	3

## 25. Battery Information

Battery	Getac, NH50BAT-4
Voltage	14,4 V
Capacity	3275mAh
Energy	approx. 48,96 Wh
Operating Time	up to 4 hours (depending on the notebook settings and user behaviour during operation)

Battery	Simplo, NH50BAT-4
Voltage	14,4 V
Capacity	3275mAh
Energy	approx. 48,96 Wh
Operating Time	up to 4 hours (depending on the notebook settings and user behaviour during operation)

---

## 26. Service information

Please contact our Customer Service team if your device ever stops working the way you want or expect it to. There are several ways for you to contact us:

- In our Service Community, you can meet other users, as well as our staff, and you can exchange your experiences and pass on your knowledge there. You will find our Service Community at <http://community.medion.com>.
- Alternatively, use our contact form at [www.medion.com/contact](http://www.medion.com/contact).
- You can also contact our Service team via our hotline or by post.

Opening times	Hotline number UK
Mon – Fri: 08.00 – 20.00 Sat – Sun: 10.00 – 16.00	☎ 0333 3213106
	Hotline number Ireland
	☎ 1 800 992508
Service address	
<b>MEDION Electronics Ltd.</b> <b>120 Faraday Park, Faraday Road, Dorcan</b> <b>Swindon SN3 5JF, Wiltshire</b> <b>United Kingdom</b>	



You can download this and many other sets of operating instructions from our service portal at [www.medion.com/gb/service/](http://www.medion.com/gb/service/). You will also find drivers and other software for a wide range of devices there.

You can also scan the QR code on the side of the screen, to download the operating instructions onto your mobile device from the service portal.

---

## 27. Legal Notice

Copyright © 2021

Date: 20.05.2021

All rights reserved.

These operating instructions are protected by copyright.

Mechanical, electronic and any other forms of reproduction are prohibited without the written permission of the manufacturer.

Copyright is owned by the distributing company:

**MEDION AG**

**Am Zehnthof 77**

**45307 Essen**

**Germany**

Please note that you cannot use the address above for returns. Please always contact our Customer Service team first.

## 28. Privacy statement

Dear customer,

We wish to inform you that we, MEDION AG, Am Zehnthof 77, 45307 Essen, Germany process your personal data as a data controller.

For matters regarding data protection, we are supported by our company data protection officer who can be contacted at MEDION AG, Datenschutz, Am Zehnthof 77, D – 45307 Essen; datenschutz@medion.com. We process your data for the purpose of warranty processing and associated processes (e.g. repairs) and therefore rely on processing your data for the sales contract concluded with us.

Your data will be provided to repairers contracted to us for the purpose of warranty processing and associated processes. We generally store your personal data for a period of three years in order to fulfil your legal warranty rights.

You have the right to be informed of the personal data concerned as well as the right to rectification, deletion, restriction of processing, the right to object to processing, as well as the right to data portability.

In case of access and cancellation rights, restrictions apply according to S 34 and S 35 of BDSG (Federal Data Protection Act) (Art. 23 GDPR). In addition, there is a right of appeal to a competent data protection supervisory authority (Article 77 GDPR in conjunction with S 19 BDSG). The state official for data protection and freedom of information for MEDION AG is Nordrhein Westfalen, P box 200444, 40212 Düsseldorf, Germany. [www.ldi.nrw.de](http://www.ldi.nrw.de).

The processing of your data is necessary for warranty processing; it is not possible to process the warranty without the provision of the required data.

---

## 29. Index

<b>B</b>	
Battery .....	49
Battery Mode .....	29
Charging the Battery .....	30
Discharging the Battery.....	30
Inserting the Battery.....	29
Removing the Battery .....	29
Bluetooth® .....	36
<b>C</b>	
Connecting	
Cabling.....	16
Power Supply.....	14
Connecting an External Monitor .....	32
Customer Service .....	43
Driver Support .....	44
Find the Cause .....	43
What To Do in Case of Hardware Problems .....	43
<b>D</b>	
Data backup .....	18
Display .....	17, 32
Opening and Closing.....	32
<b>E</b>	
Energy Saving Tips .....	31
Environmental Requirements.....	13
Ergonomics.....	18
Arms.....	19
Back.....	19
General .....	19
Head .....	19
Legs.....	19
Wrists.....	19
<b>F</b>	
Factory settings	
System restore .....	39
FAQ – Frequently Asked Questions.....	41
<b>I</b>	
Included with your Notebook.....	20
<b>K</b>	
Keyboard .....	32
Shortcuts.....	33
<b>L</b>	
Licence Agreement.....	28
<b>N</b>	
Network Operation.....	34
Requirements.....	35
Wi-Fi (Wireless Network) .....	34
Notes for Service Technicians .....	47
<b>O</b>	
Operational Safety .....	10
<b>P</b>	
Pixel Defect Types.....	48
Power Management (Power Options) .....	31
Power Supply .....	26
On/Off Switch.....	26
Preparation for Starting-Up.....	27
Proper Use.....	7
<b>R</b>	
Recycling .....	47
Repair.....	46
<b>S</b>	
Securing Your Notebook.....	37
Kensington Security Lock .....	37
Password Setting (Power-on) .....	37
Setup Location .....	12
Sound System.....	34
External Audio Connections .....	34
Starting the Notebook.....	28
System restore .....	39
PowerRecovery .....	39
Restoring the factory settings.....	39
<b>T</b>	
Touchpad.....	17, 33
Transport .....	44
<b>U</b>	
UEFI Configuration.....	41
Upgrading/Modifying.....	46
USB Port .....	36