

CASE OVERVIEW

Gehäuseübersicht | Vue d'Ensemble du Boîtier | Vista generale del contenitore | Información de la caja | 機箱概述 | 产品特点 | 케이스 개요 | ケース概要

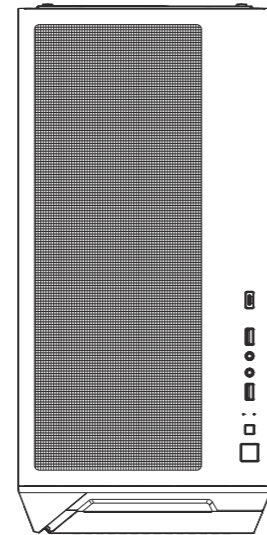

Top

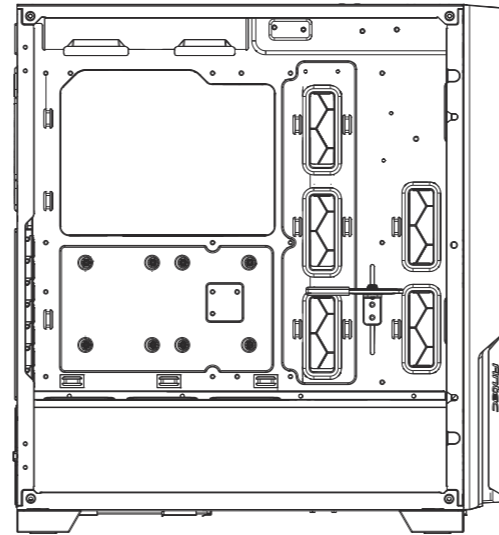

Left Side

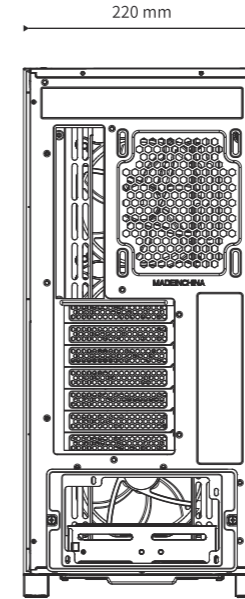

Rear

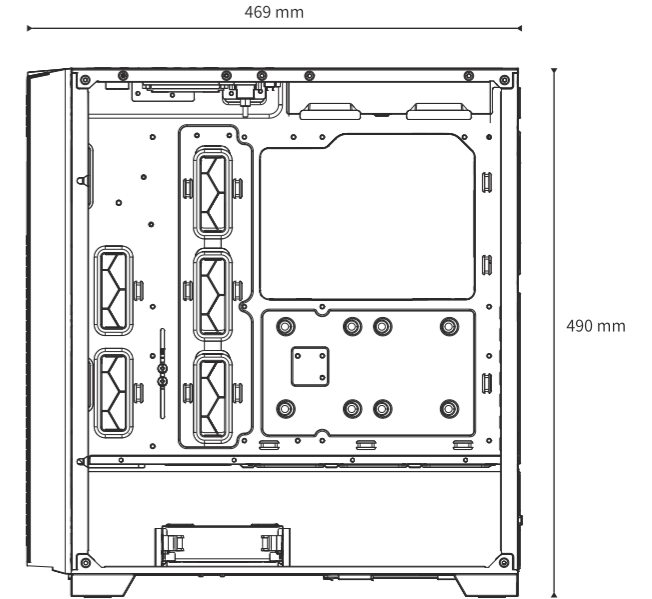

Right Side

P20C

PERFORMANCE SERIES

INFORMATION GUIDE

1 REMOVE SIDE PANEL

Seitenwand abnehmen | Retirer les Panneaux Latéraux | Rimozione del pannello laterale | Extracción de panel lateral | 拆除側面板 | 拆除側板 | 측면 패널 제거 | 側面のパネルを外す

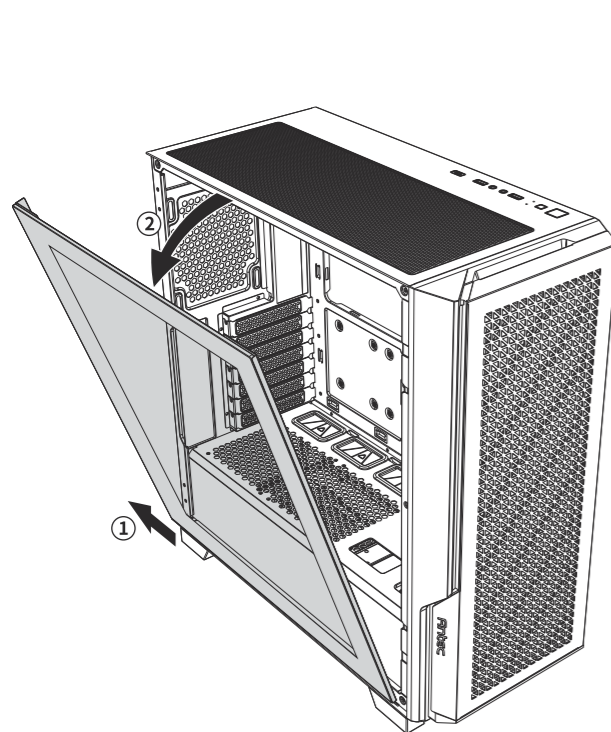

2 MOTHERBOARD INSTALLATION

Installation der Hauptplatine | Installation de la Carte-Mère | Installazione della scheda madre | Instalación de placa base | 安裝主機板 | 安裝主板 | 메인보드 설치 | 마ザー보드設置

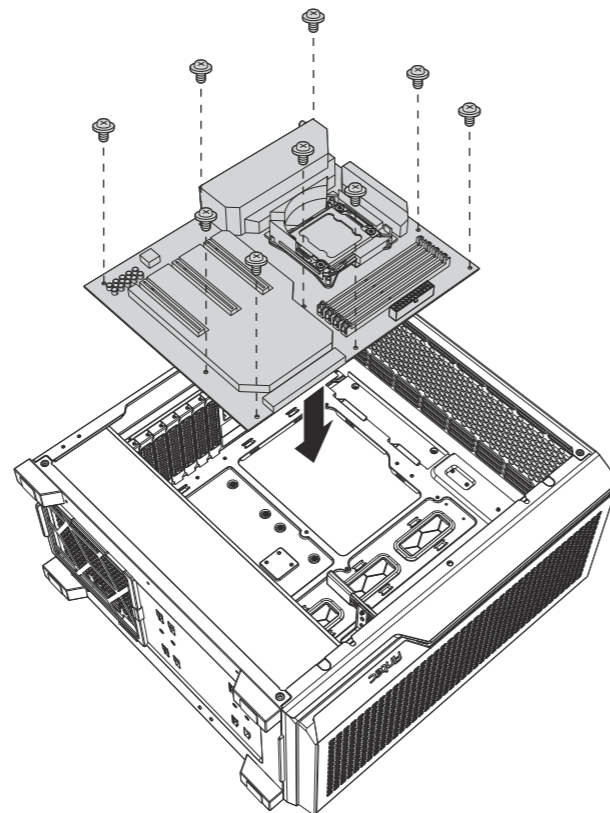

3 VGA / PCI-EXPRESS CARD INSTALLATION

Installation der VGA/PCI-Express-Karte | Installation de la Carte Graphique | Installazione della scheda VGA / PCI-Express | Instalación de tarjeta VGA/PCI-Express | 安裝VGA/PCI-E卡 | 安裝VGA/PCI-E卡 | 安裝VGA/PCI-E卡 | VGA / PCI-익스프레스 카드 설치 | VGA / PCI-E카드의設置

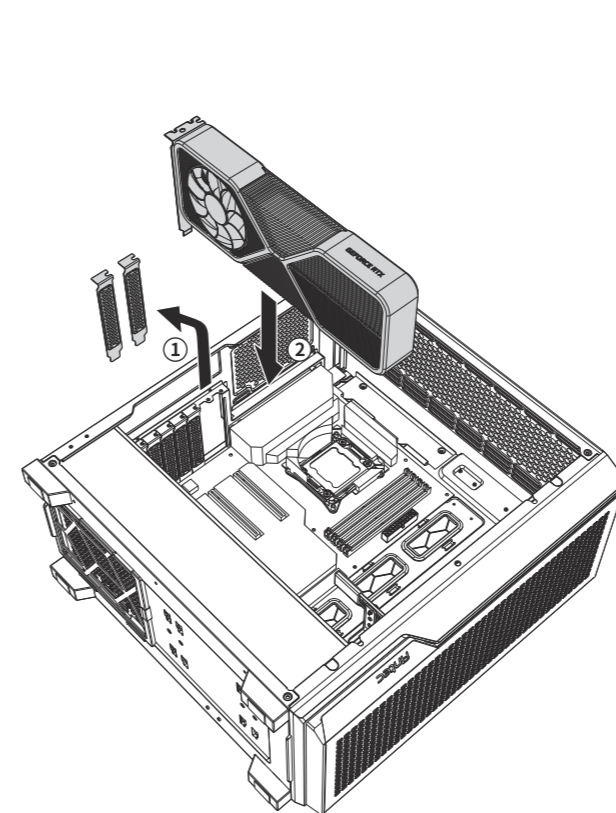

4 POWER SUPPLY INSTALLATION

Installation des Netzteils | Installation du Bloc d'Alimentation | Installazione dell'alimentatore di rete | Instalación de fuente de alimentación | 安裝電源供應器 | 安裝電源 | 파워 서플라이 설치 | 電源設置

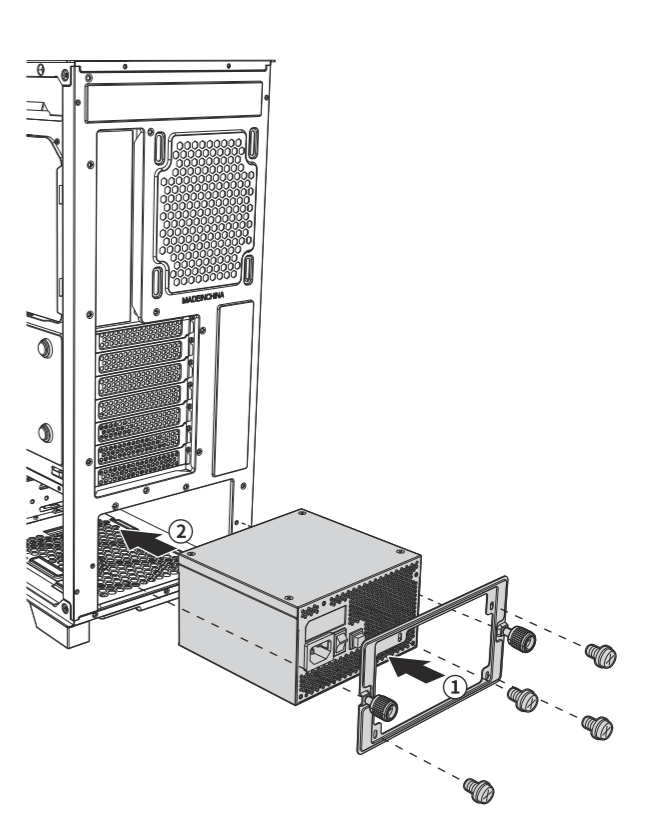

5 HARD DISK INSTALLATION

Festplatteninstallation | Installation des Disques Durs | Installazione del disco rigido |
 Instalación de disco duro | 安裝硬碟 | 安裝硬盘 | 하드 디스크 설치 | ハードディスクの設置

[A] INSTALLING A 3.5" HARD DISK DRIVE

Installation einer 3,5" Festplatte | Installer un Disque Dur 3.5" | Installazione di un disco rigido da 3.5" | Instalación de unidad de disco duro de 3,5" | 安裝3.5吋HDD硬碟 | 安裝3.5吋HDD硬盘 | 3.5" 하드 디스크 드라이브 설치 | 3.5인치 하드디스크의設置

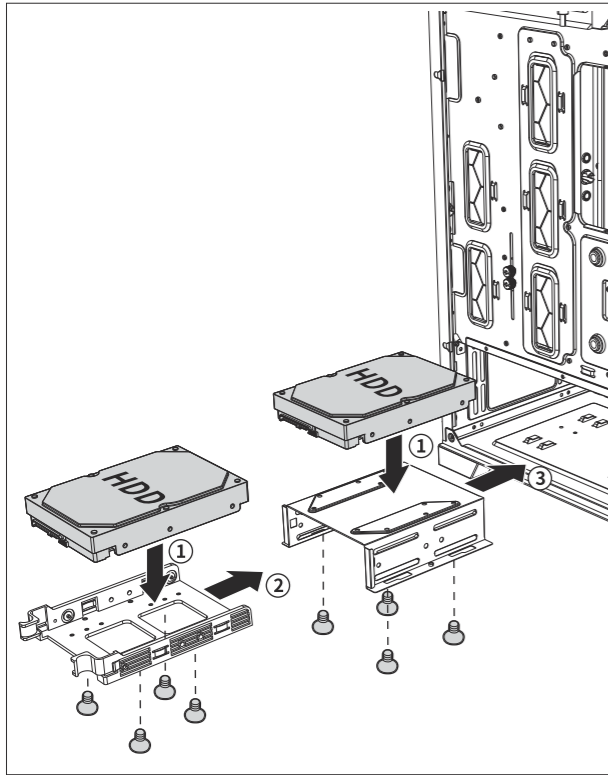

[B] INSTALLING A 2.5" SOLID STATE DRIVE

Installation einer 2,5" SSD (Solid State Drive) | Installer un Disque Dur/SSD 2.5" | Installazione di un disco a stato solido da 2.5" | Instalación de disco de estado sólido de 2,5" | 安裝2.5吋SSD固態硬碟 | 安裝2.5吋SSD固態硬盘 | 2.5" SSD 설치 | 2.5인치솔리드스테이트드라이브의設置

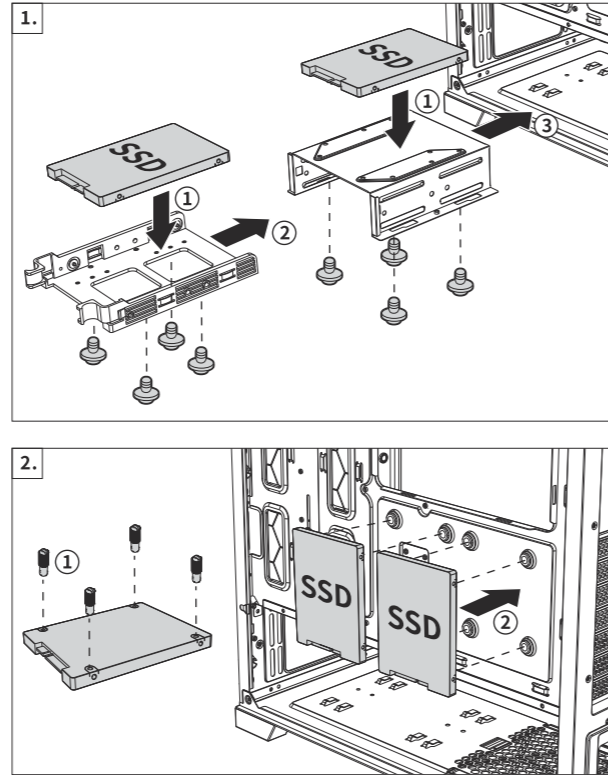

6 LIQUID COOLING RADIATOR INSTALLATION

Installation des Kühlers für die Flüssigkeitskühlung | Installation des Radiateurs
 Watercooling | Installazione del radiatore di raffreddamento liquido | Instalación de radiador
 de refrigeración líquida | 安裝水冷散熱器 | 安裝水冷散熱器 | 액체 냉각 라디에이터 설치 | 液体
 冷却ラジエーターの設置

[A] FRONT RADIATOR

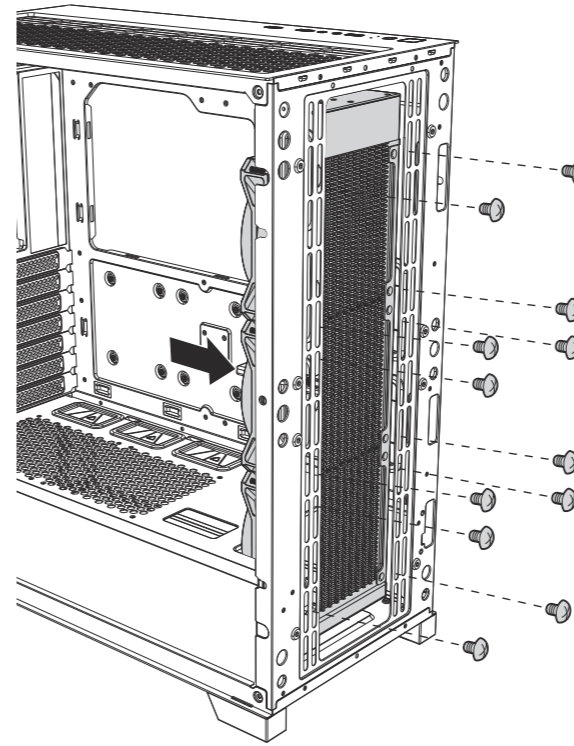

[B] TOP RADIATOR

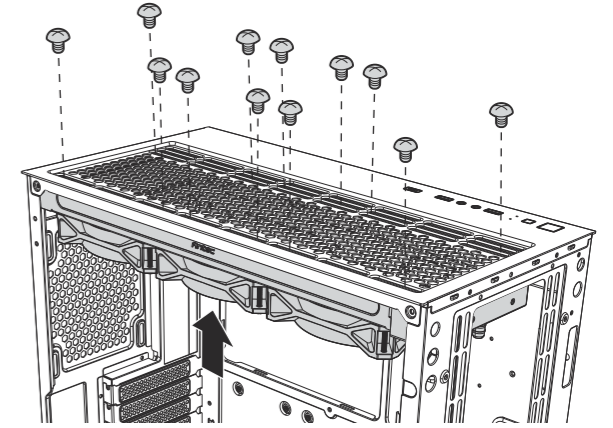

[C] REAR RADIATOR

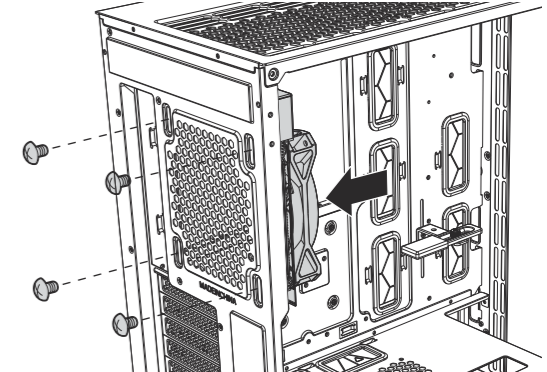

7 FAN INSTALLATION

Installation des Lüfters | Installation des Ventilateurs | Installazione del ventilatore |
 Instalación de ventilador | 安裝風扇 | 安裝風扇 | 팬 설치 | 팬의取り付け

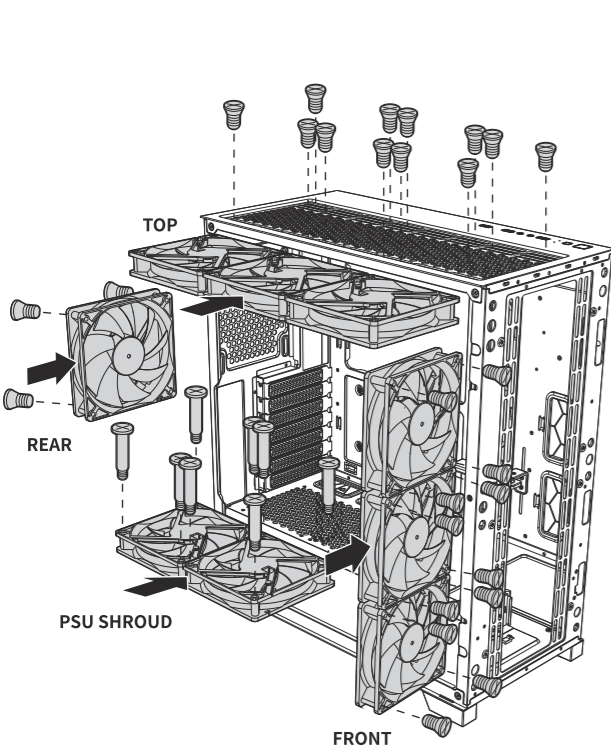

8 GPU BRACKET ADJUSTMENT

Anpassung der GPU-Halterung | Réglage de Support de GPU | Regolazione della staffa della
 GPU | Ajuste de Montaje de GPU | 顯示卡支架調整 | 顯示卡支架調整 | GPU 브라켓 조정 | GPU
 홀더의調整

[A] ADJUST HEIGHT

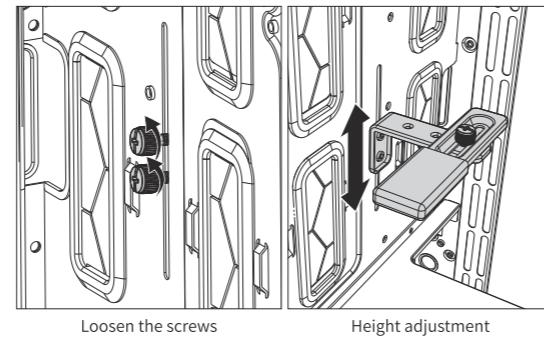

[B] ADJUST THE HOLDING POSITION

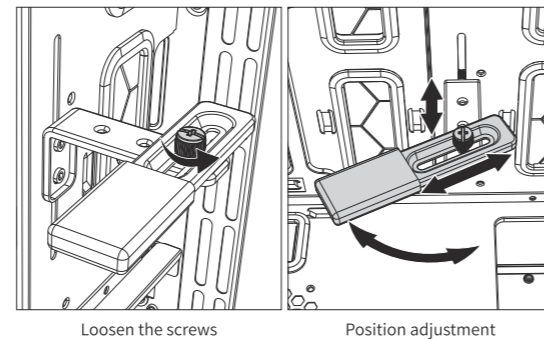

9 1 TO 4 FAN SPLITTER CABLE INSTALLATION

1 bis 4 Lüfter-Splitter-Installation | Installation du répartiteur de câbles de 1 à 4 ventilateurs
 | Installazione del cavo sdoppiatore da 1 a 4 ventole | Instalación de Cable Splitter de
 Ventilador de 1 a 4 | 1分4風扇分接線 | 1分4風扇分接線 | 1 to 4 팬 분리 케이블 | 팬의接続

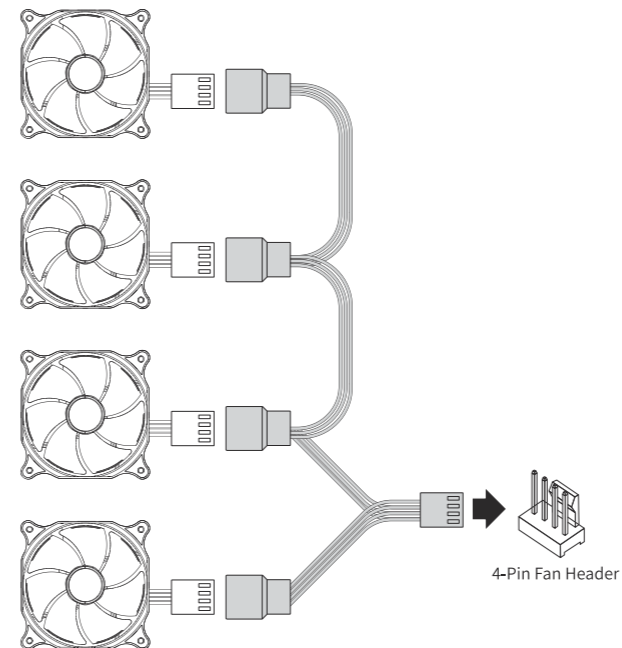

Antec
 BELIEVE IT

www.Antec.com

All rights reserved. Specifications are subject to change without prior notice.
 Actual products and accessories may differ from illustrations. Omissions and
 printing errors excepted. Content of delivery might differ in different countries
 or areas. Some trademarks may be claimed as the property of others.

V2.2

©1986 - 2022 Antec, Inc. All rights reserved.